

Rezoning Transportation Analysis

Petition Number: 2020-038

General Location Identifier: Tax ID 20143102

From: Robyn Byers, PhD

Robyn.Byers@charlottenc.gov

704-336-7404

Reviewer: Kevin Parker, PE

Kevin.Parker@charlottenc.gov

704-432-6511

Revision Log:

Date	Description
04-22-2020	First Review (EL)
05-19-2020	Second Review (EL)
06-25-2020	Third Review (EL)
08-20-2020	Fourth Review (KP)
09-17-2020	Fifth Review (KP)

General Review Information

The site is located on Cedar Crossings Drive, a city maintained local street, in a wedge outside of Route 4. The site is located within the Steele Creek Area Plan.

Active Projects Near the Site:

- Steele Creek Rd. Widening (NC 160) – I-485 to South Carolina line
 - Project scope: Widen existing NC 160 to a 4-lane superstreet with multi-use paths (6 lanes in some areas)
 - ROW Year 2021 (project is currently on-hold)
 - Construction Year 2024 (project is currently on-hold)
 - PM: NCDOT
 - TIP #: U-5766

CDOT's review of this rezoning petition is intended to provide consistency with council adopted policies, plans, standards and guidelines including, but not limited to, the [Transportation Action Plan \(TAP\)](#), [Vision Zero](#), [Urban Street Design Guidelines \(USDG\)](#), [Center, Corridor and Wedges](#), [Charlotte BIKES](#), [Traffic Impact Study Guidelines](#) and [Charlotte WALKS](#). With a commitment to design complete streets, this review is to ensure that the City's transportation network supports current and future land uses and includes streets that provide safe and comfortable mobility for motorists, pedestrians, bicyclists, and transit users.

This document is primarily for communication to Planning Department staff as part of the overall City staff analysis of the rezoning petition and includes an overall summary of the case from a transportation perspective, information on trip generation, and resolved or outstanding site plan concerns. Additional advisory information about the driveway permit process is provided for information only.

Based on our review of the petition, we offer the following information for your consideration.

Transportation Summary

The site is located within the Cedar Ridge Subdivision, off of Steele Creek Road, with access off of Cedar Crossings Drive. The petitioner has agreed to install a 12-ft multi-use path along the site's frontage of Steele Creek Road in accordance with the City's BIKES plan. Additionally, the petitioner has agreed to construct left and right turn lanes on Steele Creek Road, to mitigate the additional traffic impacts as a

Rezoning Transportation Analysis

Petition Number: 2020-038

General Location Identifier: Tax ID 20143102

result of this development. In all, with the pedestrian and vehicular improvements, the overall transportation network will improve in the area.

A new site plan with access off of Cedar Crossings was provided on 08-17-2020, requiring a substantial review. This site plan needs revision to address updated comments, outstanding comments, and new comments based off of the new site plan. These include labeling and dimensioning a right-turn lane. Please note that all CDOT reviews have included a comment to add a left-turn lane onto Erwin Rd to help ease congestion in the area, however, this is not a requirement for approval and has not been agreed to by the petitioner.

Trip Generation

Scenario	Land Use	Intensity	Trip Generation (vehicle trips/day)	Source
Existing Use	Single Family	1 DU	9	Tax Record
Entitlement with Current Zoning	Single Family (R-3, 9.96 acres)	29 DU	335	General Guidance from Planning
Proposed Zoning	Apartments	419 DU	650	Site Plan: 02-14-20
	Senior Apartments	119 DU	450	Site Plan: 09-14-20

Please provide responses to our comments.

Outstanding Issues

Strikeout = Not an outstanding issue

1. ~~**Curblin**~~ The proposed zoning district has a setback measured from back of the existing or proposed future curblin.
 - a. ~~**Steele Creek Road:**~~ Location of curb and gutter needs to be shown on the plans based on the NCDOT TIP Project (U-5766) NC 160. The curb and gutter doesn't need to be constructed, but it does need to be shown on the plans.

The site plan should show the curb and gutter labeled and dimensioned from the centerline for each road.

2. ~~**Traffic Study**~~ A Traffic Impact Study is not necessary for the complete review of this petition due to the site generation more than 2500 daily trips. If during the permitting process the site generates more than 2500 daily trips, then a traffic study will be required.

3. The petitioner should revise the site plan and conditional note(s) to commit to dedicate right of way from the road centerline for the NCDOT TIP Project (U-5766) NC 160. You can contact NCDOT for the exact location of the curb and gutter. The site plan should label and dimension the right-of-way from the road centerline.
 - a. ~~**New Comment based on revised site plan dated 4-1-2020:**~~ Please review the NC 160 cross section provided below to revise the site plan to include the correct curb line and right of way location.
 - b. ~~**Technical Clarification based on revised site plan dated 6-23-2020**~~ Please revise the site plan to revise the proposed right of way dedication to +/- 60 feet, measured from road centerline.

Rezoning Transportation Analysis

Petition Number: 2020-038

General Location Identifier: Tax ID 20143102

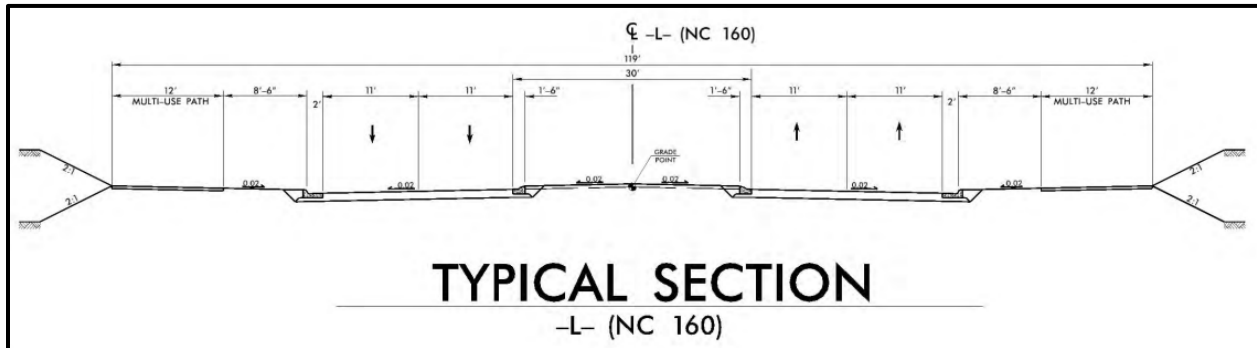

Outstanding with clarifying language added with 08-17-20 site plan: The petitioner should revise the site plan and conditional note ([Section Transportation.7.](#)) to commit to a north-eastbound 100' right-turn lane ~~into the~~ from NC 160 into Erwin Drive. Please clearly label and dimension the right turn lane. **Updated Comment from 09-14-2020 Site Plan:** It appears this right turn lane is there, however, it is not labeled nor dimensioned.

4. ~~The petitioner should revise the site plan and conditional note(s) to commit to provide a 50-foot driveway stem from the future NC 160 right of way line.~~
 - a. ~~**New Comment based on revised site plan dated 4-1-2020:** Please refer to the cross section below on the NC 160 project's Map 4 at <https://www.ncdot.gov/news/public-meetings/Pages/U-5766-2019-08-21.aspx>. This resource will provide more guidance to properly revise the driveway stem to provide 50' from the future right-of-way line. The driveway should be perpendicular with the future right of way.~~



5. **Outstanding** with clarifying language added with 08-17-20 site plan: The petitioner should revise the site plan and conditional note ([Section Transportation.7.](#)) to commit to construct a south-westbound left-turn lane with 150' of storage and appropriate left-turn lane tapers based on the speed limit from NC 160 into Erwin Drive. **Updated Comment with 09-14-2020 Site Plan:** This left turn lane has been requested during every previous review phase and in multiple resubmittal meetings. Both NCDOT and CDOT cannot require this left turn lane and, as a result, the petitioner has opted to not include this left turn lane in their site plan and scope of work. This note is not meant to deter approval of this petition, rather, this note serves to provide transparency of information from previous reviews and discussions between all parties.
6. ~~**Comment Rescinded after change of access. Outstanding** with clarifying language added The petitioner should revise the site plan and conditional note ([Section Transportation.3.](#)) to show an exhibit showing temporary full access with left turn and right turn lanes, and the future access on NC~~

Rezoning Transportation Analysis

Petition Number: 2020-038

General Location Identifier: Tax ID 20143102

~~160, based on the NCDOT NC 160 widening project. A conditional note should be added that the access will may be changed to a right in/right out access based on the NCDOT project. Please coordinate with NCDOT and provide the future permanent access that will be permitted for the NC 160 project. For the NC 160 pre-build condition, the proposed driveway design should be reconfigured to a Charlotte Land Development Standard Manual (CLDSM) or NCDOT driveway standard, and the proposed driveway monolithic median should be removed.~~

7. **Rescinded** The petitioner should revise the site plan and conditional note(s) to commit to construct an 8-foot planting strip, and 6-foot sidewalk on Cedar Crossing Drive to meet the Subdivision ordinance. The site plan should label and dimension both items from the back of curb and gutter and road centerline.
8. ~~The petitioner should revise the site plan and conditional note(s) to commit to construct an 8-foot planting strip, and 12-foot multi-use path on Steele Creek Road at its ultimate location. The site plan should label and dimension both items from the back of curb and gutter and road centerline~~
9. **Rescinded** The petitioner should revise the site plan and conditional note(s) to include an additional access point to Cedar Crossing Drive, as the Subdivision ordinance require two access points for this type of development. The access should be located opposite of Kendrick Crossing Road.
10. **Rescinded** The petitioner should revise the site plan and conditional note(s) to include a sidewalk connection from the site to the sidewalk along Cedar Crossing Drive.
11. **Outstanding with clarifying language added with 08-17-20 site plan:** ~~The petitioner should revise the site plan to add a conditional note (Section Transportation.2.) specifying dedication and fee simple conveyance of all rights of way to NCDOT and the City before the site's first building certificate of occupancy is issued. CDOT requests right of way set at 2' behind back of sidewalk where feasible.~~
12. **Outstanding with clarifying language** ~~The petitioner should revise the site plan to add a note specifying all transportation improvements will be approved and constructed before the site's first building certificate of occupancy is issued. The petitioner may phase transportation improvements if said improvements and phasing are explicitly described in site plan notes. Please include within conditional note (Section Transportation.6.) that the right and left turn lanes on NC 160 will be constructed prior to the first CO.~~
Updated comment from 09-14-2020 Site Plan: This note is directly related to the updated comment from note 5 and, as it stands, the left turn lane has been omitted.
13. **New Comment as a result of the new site plan dated 08/17/2020:** The petitioner should update the site plan and conditional notes to show an access easement along the proposed access drive from Cedar Crossing Drive. The petitioner should work with the owner of Parcel 20143101 to obtain this access easement.
Updated Comment from 09-14-2020 Site Plan: Include language in the notes that validation of this easement will be provided to CDOT before final permitting.
14. **Resolved** Sample format for comment that is resolved

Advisory Information

The following are requirements of the developer that must be satisfied prior to driveway permit approval. We recommend that the petitioner reflect these on the rezoning plan as appropriate.

1. According to the City of Charlotte's Driveway Regulations, CDOT has the authority to regulate/approve all private street/driveway and public street connections to the right-of-way of a street under the regulatory jurisdiction of the City of Charlotte.

Rezoning Transportation Analysis

Petition Number: 2020-038

General Location Identifier: Tax ID 20143102

2. Adequate sight triangles must be reserved at the existing/proposed street entrance(s). Two 35' x 35' sight triangles (and two 10' x 70' sight triangles on North Carolina Department of Transportation on NCDOT maintained streets) are required for the entrance(s) to meet requirements. All proposed trees, berms, walls, fences, and/or identification signs must not interfere with sight distance at the entrance(s). Such items should be identified on the site plan.
3. The proposed driveway connection(s) to public streets will require a driveway permit(s) to be submitted to CDOT (and the North Carolina Department of Transportation on NCDOT maintained streets) for review and approval. The exact driveway location(s) and type/width of the driveway(s) will be determined by CDOT during the driveway permit process. The locations of the driveway(s) shown on the site plan are subject to change in order to align with driveway(s) on the opposite side of the street and comply with City Driveway Regulations and the City Tree Ordinance.
4. All proposed commercial driveway connections to a future public street will require a driveway permit to be submitted to CDOT for review and approval.
5. Any fence or wall constructed along or adjacent to any sidewalk or street right-of-way requires a certificate issued by CDOT.
6. A Right-of-Way Encroachment Agreement is required for the installation of any non-standard item(s) (irrigation systems, decorative concrete pavement, brick pavers, etc.) within a proposed/existing City maintained street right-of-way by a private individual, group, business, or homeowner's/business association. An encroachment agreement must be approved by CDOT prior to the construction/installation of the non-standard item(s). Contact CDOT for additional information concerning cost, submittal, and liability insurance coverage requirements.