

NOTES:

1. THIS DETAIL CAN ONLY BE USED WITH APPROVAL FROM CDOT OR NCDOT. 1'-6" CURB & GUTTER OR VERTICAL CURB PEDESTRIAN REFUGE DETAILS ARE PREFERRED.
2. PROPOSED ASPHALT PATCH LAYER THICKNESS WILL VARY AS REQUIRED BY CDOT OR NCDOT.
3. ENSURE PEDESTRIAN PASS-THRU HAS ADEQUATE SLOPE DRAINAGE AND DOES NOT POND WATER.
4. NCDOT REQUIRES MILLING AND OVERLAY TO SEAL JOINT AT SAWCUTS SHOWN. FOR CITY STREETS MILLING AND OVERLY MAY BE REQUIRED.
5. NCDOT REQUIRES 1' OFFSET FROM EDGE OF PAVEMENT ALONG CURBLINE TO LANE LINE.
6. NCDOT REQUIRES THAT ALL JOINTS BE SEALED PER NCDOT STANDARD.
7. USE "QWICK KURB L104 REFLECTIVE YELLOW PADDLE" OR EQUIVALENT.

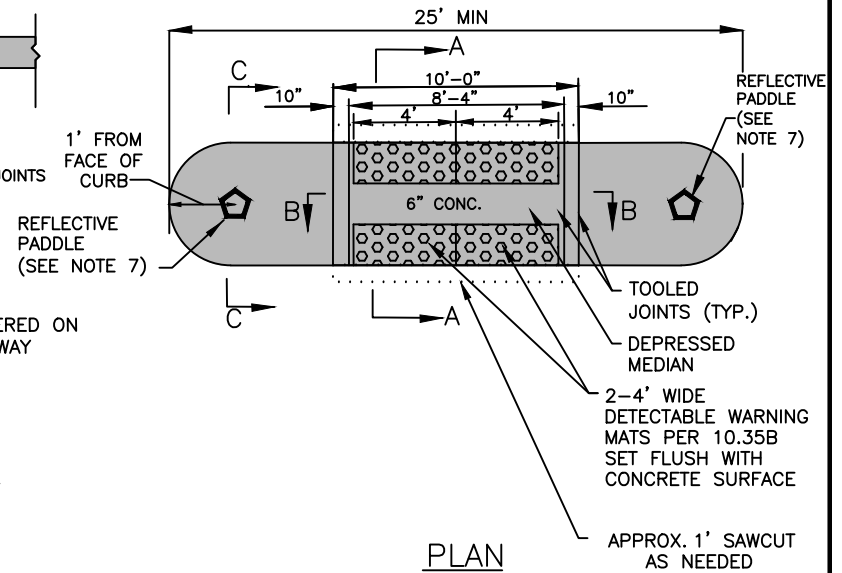

NOT TO SCALE

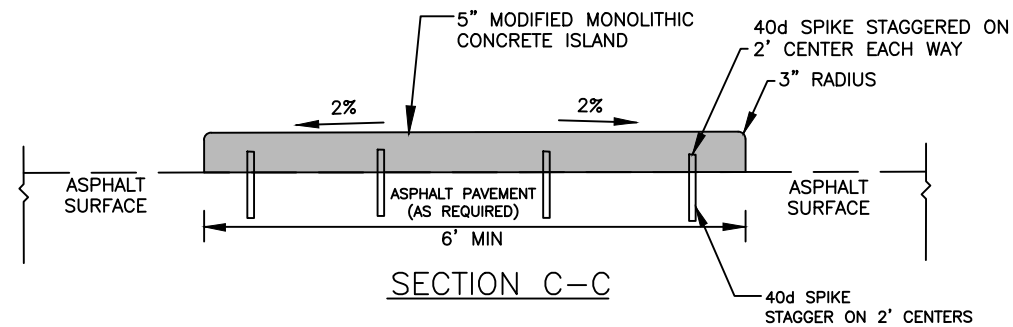
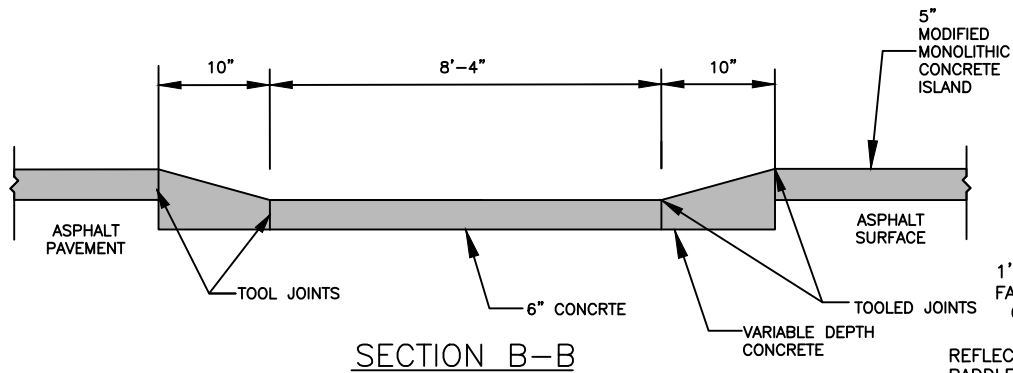

CITY OF CHARLOTTE  
LAND DEVELOPMENT STANDARDS  
INCLUDES CHARLOTTE ETJ

PEDESTRIAN REFUGE  
(MODIFIED MONOLITHIC)

STD. NO.	REV.
10.41C	17