

** = SAWCUT AS NEEDED IF INSTALLED IN EXISTING PAVEMENT

NOTE:

1. THIS DETAIL MAY BE USED ON NCDOT-MAINTAINED STREETS ONLY WITH APPROVAL FROM NCDOT.
2. PROPOSED ASPHALT PATCH LAYER THICKNESS WILL VARY AS REQUIRED BY CDOT OR NCDOT.
3. ENSURE PEDESTRIAN PASS-THRU HAS ADEQUATE SLOPE DRAINAGE AND DOES NOT POND WATER.
4. STAMPED/COLORED CONCRETE PATTERN AND COLOR MAY BE ALTERED WITH CDOT APPROVAL.
5. THIS DETAIL MAY BE USED TO PROVIDE A PEDESTRIAN REFUGE PASS-THRU IN AN EXISTING MEDIAN WITH 1'-6" CURB & GUTTER.
6. FOR 1'-6" CURB AND GUTTER, USE CLDSM 10.17A FOR CITY STREETS OR NCDOT 846.01 FOR NCDOT STREETS.
7. NCDOT REQUIRES MILLING AND OVERLAY TO SEAL JOINT AT SAWCUTS SHOWN. FOR CITY STREETS MILLING AND OVERLAY MAY BE REQUIRED.
8. NCDOT REQUIRES 1' OFFSET FROM EDGE OF PAVEMENT ALONG CURBLINE TO LANE LINE.
9. NCDOT REQUIRES THAT ALL JOINTS IN THE ISLAND MUST BE SEALED PER NCDOT STANDARD.
10. USE "QWICK KURB L104 REFLECTIVE YELLOW PADDLE" OR EQUIVALENT.

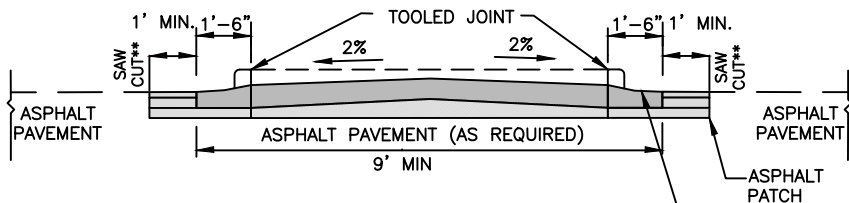

SECTION A-A

SLOPE ON DEPRESSED CURB AT DOMES CANNOT EXCEED 8.33%

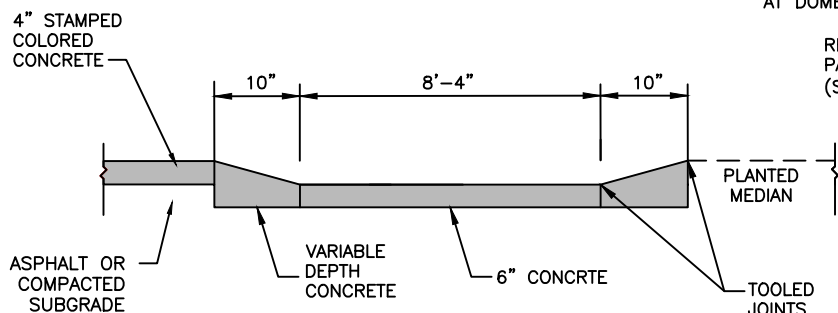

SECTION B-B

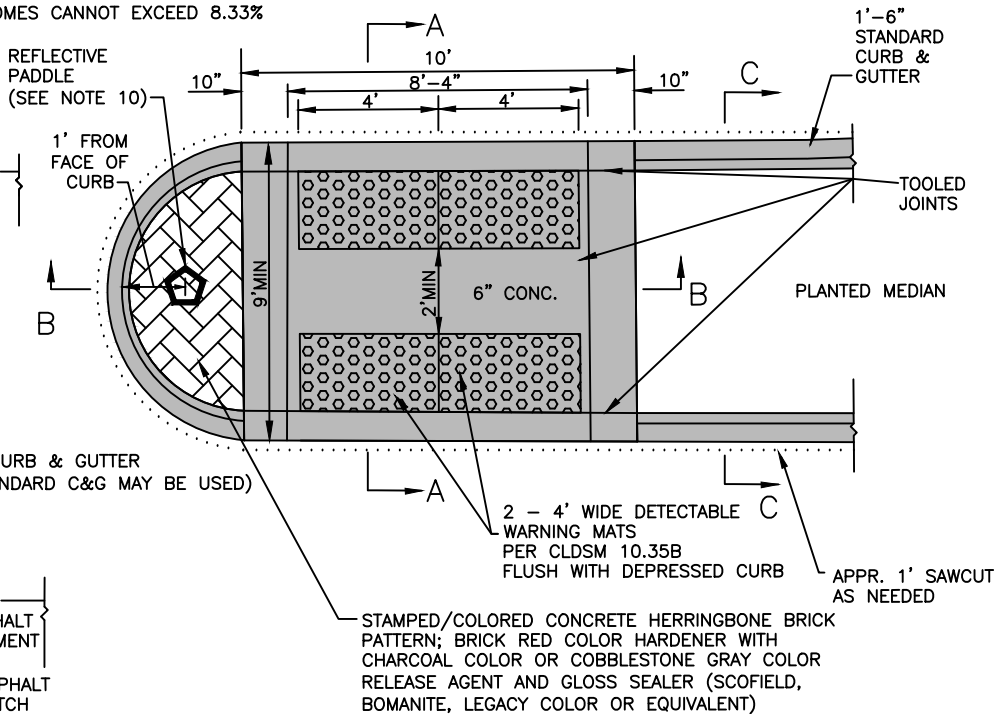

PLAN

NOT TO SCALE



CITY OF CHARLOTTE
LAND DEVELOPMENT STANDARDS
INCLUDES CHARLOTTE ETJ

PEDESTRIAN REFUGE
(WITH 1'-6" CURB & GUTTER)

STD. NO.	REV.
10.41A	17