

**NOTES:**

1. TO BE USED ON ROADS WITHOUT CURB AND GUTTER AND WHERE CURB AND GUTTER IS NOT BEING INSTALLED. (MUST MEET BOTH CRITERIA)
2. ALL CONCRETE TO BE 3600 P.S.I. COMPRESSIVE STRENGTH.
3. THIS STANDARD IS TYPICALLY FOR COMMERCIAL APPLICATION. FOR RESIDENTIAL DRIVEWAY CONSTRUCTION, USE AT THE DISCRETION OF THE CITY.
4. "A" BREAKOVER SHALL BE 8% OR LESS.
5. ALL CONCRETE TO BE 3600 P.S.I.
6. \*\* PER NC IFC SECTION D103.2, FIRE APPARATUS ACCESS ROADS SHALL NOT EXCEED 10 PERCENT IN GRADE.
7. ALL DRIVEWAYS MUST MEET THE CURRENT CITY DRIVEWAY REGULATIONS AND NCDOT REQUIREMENTS FOR SPACING, SIGHT DISTANCE, AND OFFSETS FROM PROPERTY LINES AND INTERSECTIONS.
8. PRIOR APPROVAL IS REQUIRED BY CDOT ON GRADES EXCEEDING WHAT ARE SHOWN.
9. JOINT MATERIAL SHOULD BE PLACED FLUSH WITH CONCRETE.

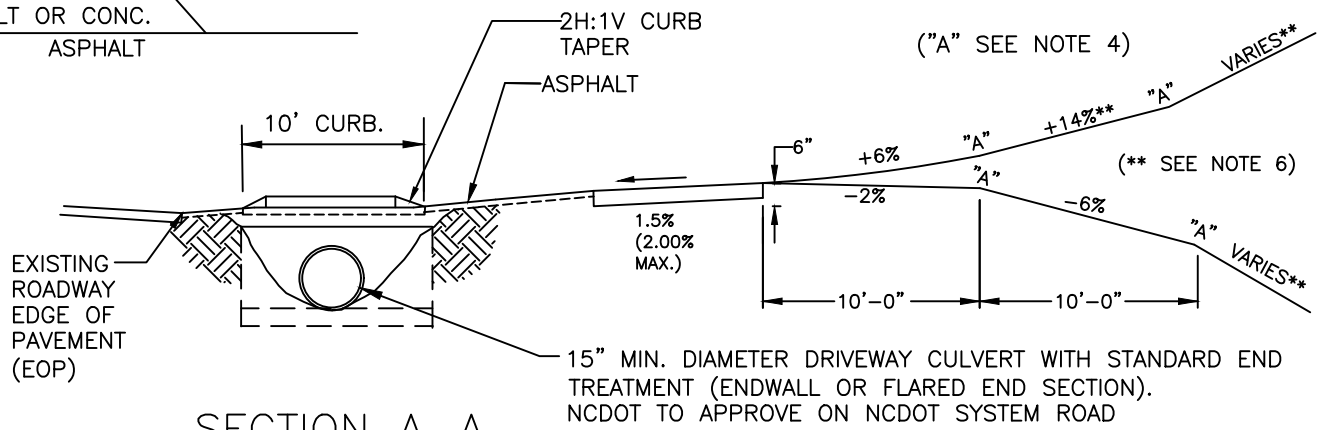

DRIVEWAY WIDTH		
DRIVEWAY TYPE	MINIMUM	MAXIMUM
RESIDENTIAL: LOCAL/COLLECTOR THOROUGHFARE*	10'	30'
ONE-WAY COMMERCIAL	20'	30'
TWO-WAY COMMERCIAL	26'	50'

\* MUST PROVIDE ON-SITE TURNAROUND

**SECTION A-A**



**CITY OF CHARLOTTE  
LAND DEVELOPMENT STANDARDS**  
INCLUDES CHARLOTTE ETJ

**TYPE IV DRIVEWAY**

NOT TO SCALE

STD. NO.	REV.
10.25F	20