

TRUE BOLT ON S.S. HINGES. HINGES IN FOUR CORNERS WITH ANGLE SUPPORTS AT EACH FRAME EDGE. SEE DETAIL "B"

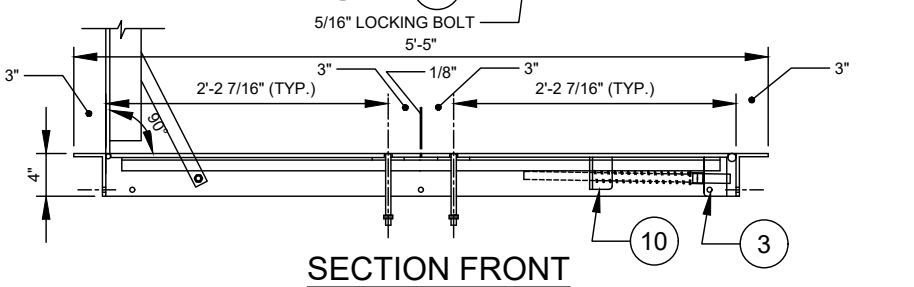

SECTION FRONT

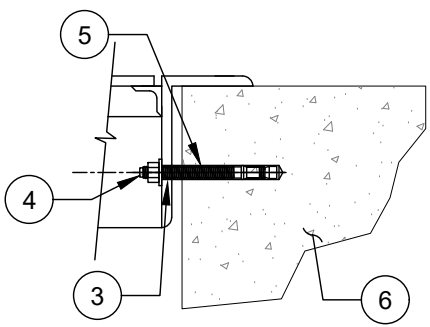
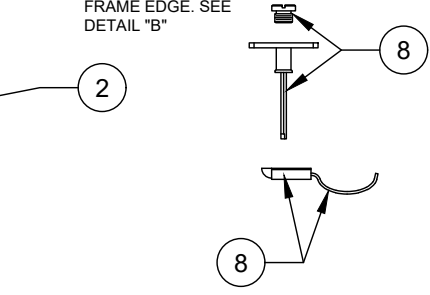

ANCHOR DETAIL

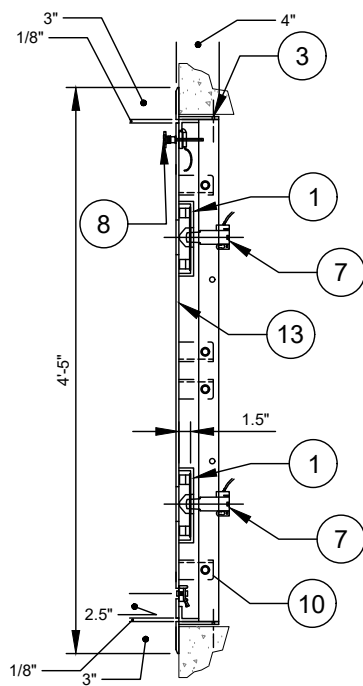

SECTION SIDE

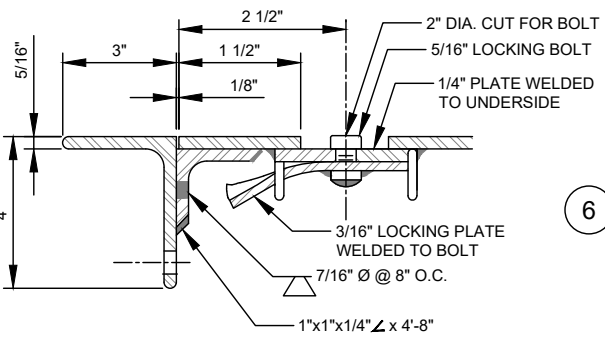

DETAIL A - LOCKING BOLT (1 EA)

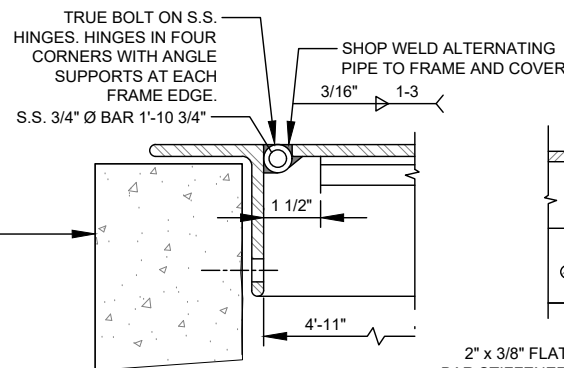

DETAIL B HINGE

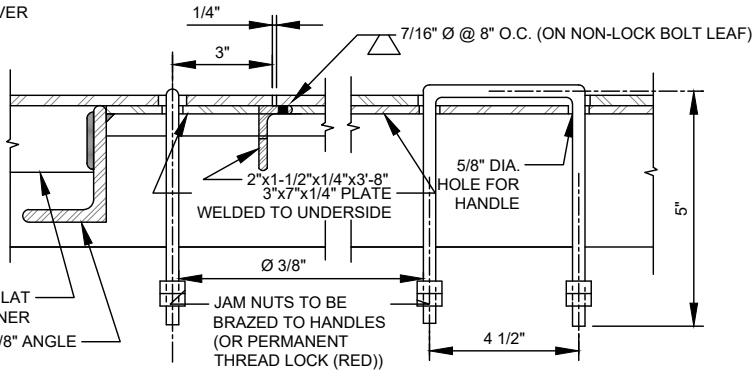

DETAIL C HANDLE (4)

DETAIL D HANDLE

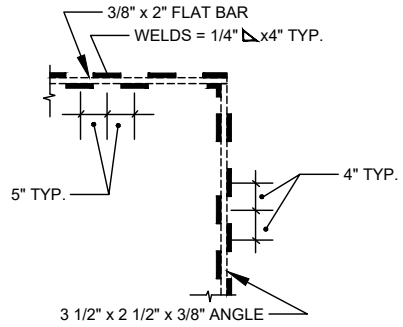

STIFFENER WELD DETAIL "F"

NO. DESCRIPTION:

1. TRANSMITTER SUPPORT BRACKET (SEE STANDARD DETAIL).
2. 2" LETTERING MILLED INTO DOOR LEAF.
3. 9/16-INCH DIAMETER DRILLED HOLE (10 EACH).
4. 1/2-INCH DIAMETER X 4-1/2-INCH STAINLESS STEEL EPOXY ADHESIVE ANCHOR - (RED HEAD, HILTI OR APPROVED EQUAL).
5. 1/2-INCH DIAMETER DRILLED HOLE IN CONCRETE.
6. CONCRETE VAULT OR PEDESTRIAN SIDEWALK.
7. WATER METER TRANSMITTER.
8. SLAM LOCK/THREADED PLUG / REMOVABLE KEY / INSIDE HANDLE.
9. RECESSED PADLOCK ASSEMBLY (STANDARD SIZE) WITH STAPLE / SPRING LOADED HINGED LID.
10. OPEN COMPRESSION SPRING ASSEMBLY (# AS REQUIRED) - HORIZONTALLY MOUNTED.
11. PADLOCK TO BE FURNISHED BY CLTW.
12. AUTOMATIC HOLD OPEN ARM WITH VINYL GRIP.
13. ATTACH ENGRAVED LABEL, WITH PREMISE NUMBER, TO UNDERSIDE OF DOOR, NEAR THE LIFTING HANDLE.

DESIGN REQUIREMENTS:

- a. MATERIAL - STRUCTURAL STEEL - ASTM A-36.
- b. LIVE LOAD - 1,000 LBS. / SQ. FT. MINIMUM - PEDESTRIAN LOADING. MAXIMUM DEFLECTION 1/150 TH. OF SPAN.
- c. DOOR LEAF - 1/4-INCH THICK DIAMOND PLATE.
- d. COMPRESSION SPRINGS AND HOLD OPEN BAR ASSEMBLY ARE REQUIRED ON EACH LEAF.
- e. SLAM LOCK / HOLD OPEN ARM - STAINLESS STEEL - TYPE 300.
- f. COMPRESSION SPRING ASSEMBLY - STAINLESS STEEL - TYPE 300.
- g. FORCE REQUIRED TO OPEN LEAF (W/SPRINGS) SHALL BE MINUS 5 LBS. MINIMUM AND 20 LBS. MAXIMUM.
- h. TRUE BOLT ON S.S. HINGES WITH SUPPORT ANGLES - TYPE 304 STAINLESS STEEL.

NOTES:

- A. CONTRACTOR SHALL ANCHOR FRAME USING ANCHOR HOLE NO. 4 - AS APPROVED (ANCHOR DETAIL).
- B. FRAME AND COVER TO BE HOT DIP GALVANIZED. ENTIRE ASSEMBLY SHALL BE GALVANIZED. GALVANIZED COATING SHALL BE A MINIMUM OF 3.9MLS PER ASTM A123 GRADE 100.
- C. FRAME DIMENSIONS SHALL ALLOW FOR CLOSE FIT INSIDE VAULT AS SHOWN AT TOP OF VAULT WALLS.
- D. STIFFENER TO BE WELDED TO BACK OF ACCESS DOOR USING WELD PATTERN AS SHOWN.
- E. COMPRESSION SPRING ASSEMBLY SHALL BE DESIGNED BY MANUFACTURER TO CONFORM TO LIFTING FORCE REQUIREMENTS - NUMBER OF SPRINGS AS REQUIRED.
- F. STAINLESS STEEL FOR ALL HARDWARE.

WARNING NOTE:

THIS DOOR IS NOT TO BE USED IN OR ADJACENT TO DRIVEWAYS OR ANY AREA SUBJECT TO VEHICLE WHEEL LOADS, OR ANY LOAD GREATER THAN 1,000 PSF.