

PLAN - SUPPORT BRACKET

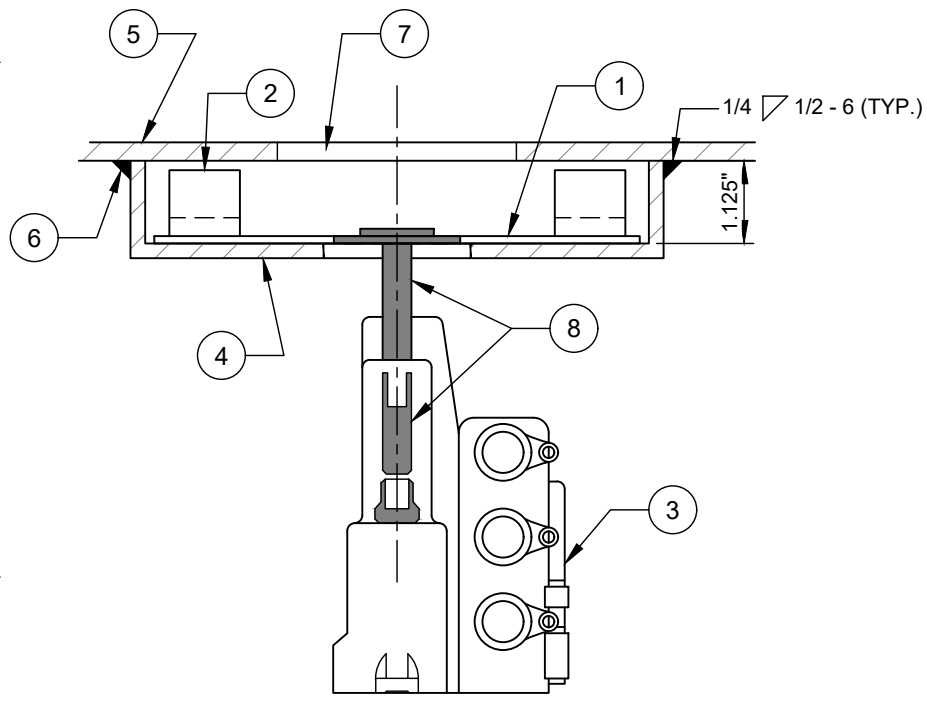

SECTION "A-A" -
SUPPORT BRACKET

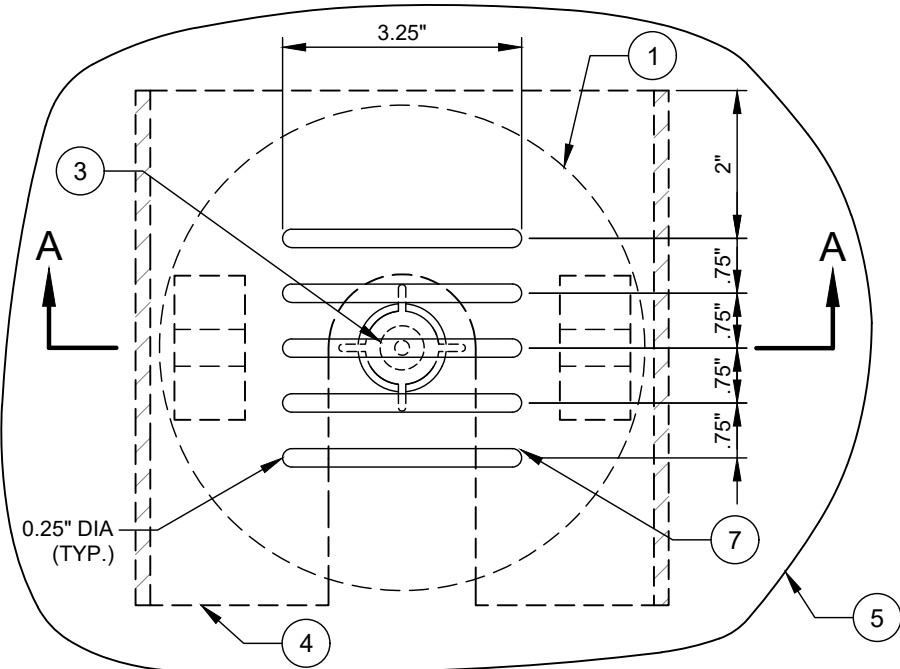

PLAN - TRANSMITTER SLOT DETAIL

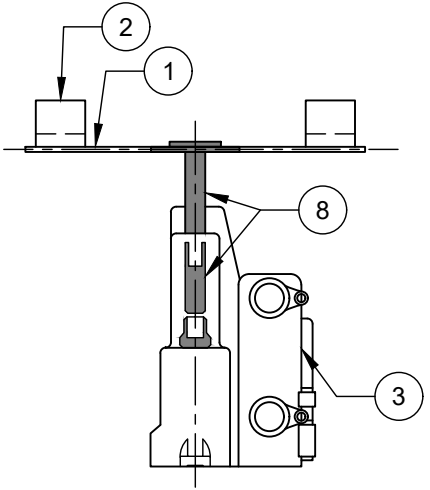

WITH 100W ADAPTER

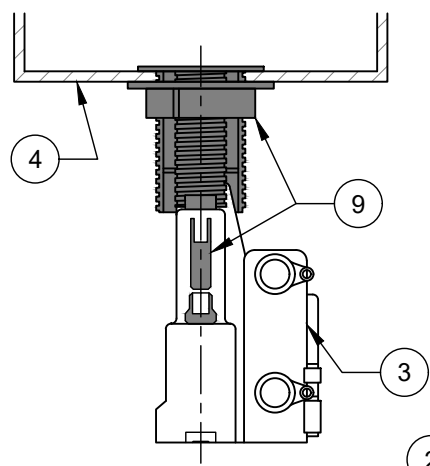

WITH 500W ADAPTER

SECTION - TRANSMITTER &
SHELF MOUNT DISC

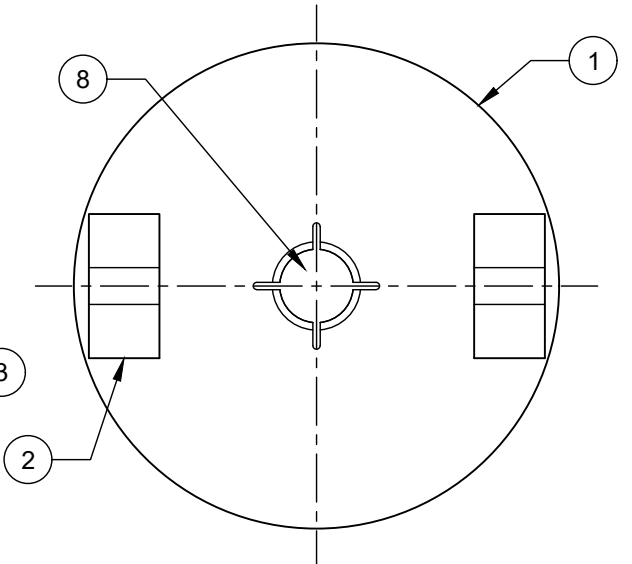

PLAN - SHELF MOUNT DISC

NO.	DESCRIPTION:
1.	ITRON 6.7" DIAMETER SHELF MOUNT DISC WITH FOAM SPACERS.
2.	FOAM SPACERS 2 EACH (TYPICAL).
3.	ITRON END POINT TRANSMITTER.
4.	SUPPORT BRACKET (1/4" STEEL PLATE).
5.	DIAMOND PLATE DOOR LEAF.
6.	FILLET WELD SUPPORT BRACKET AT CORNERS.
7.	TRANSMITTER SLOTS - 5 EA. AS SHOWN.
8.	ITRON 100W ADAPTER.
9.	ITRON 500W ADAPTER.

- NOTES:**
- A. ONE SUPPORT BRACKET REQUIRED FOR EACH METER IN VAULT.
 - B. ITRON 100W ADAPTER SHALL BE SNAPPED INTO SHELF MOUNT DISC AND ITRON 100W ERT TRANSMITTER. ITRON 500W ADAPTER SHALL BE TIGHTLY ATTACHED TO THE SUPPORT BRACKET SLOT AND ITRON 100W TRANSMITTER.
 - C. TRANSMITTER/MOUNT ADAPTER SHALL BE INSERTED INTO SUPPORT BRACKET AS SHOWN.
 - D. DOOR LEAF AND SUPPORT BRACKET SHALL BE OF LIKE MATERIALS.
 - E. SEE ACCESS DOOR STANDARD DETAILS FOR SUPPORT BRACKET LOCATIONS.