

3/4-INCH SERVICE LID

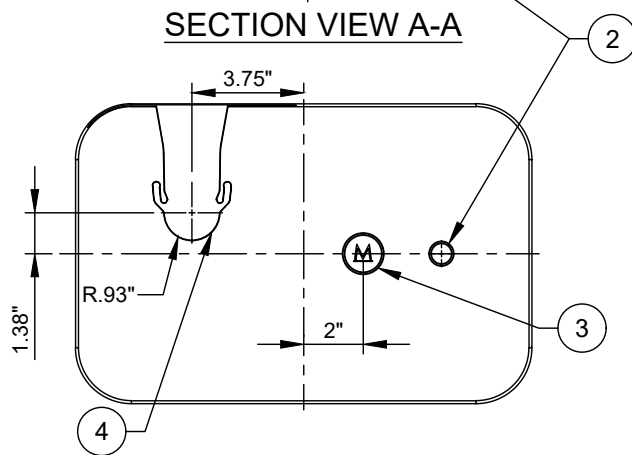

SOUTHEASTERN DISTRIBUTORS - MB16 HD - LID WEIGHT - INCLUDING MAGNET - 6 LBS.

1-INCH SERVICE LID

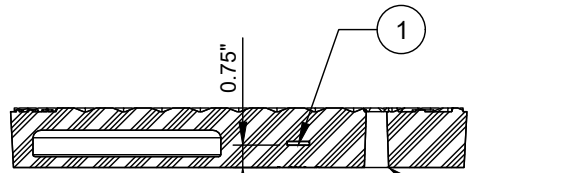
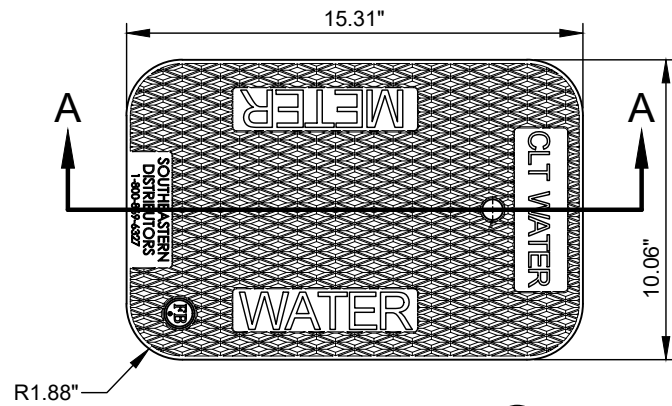
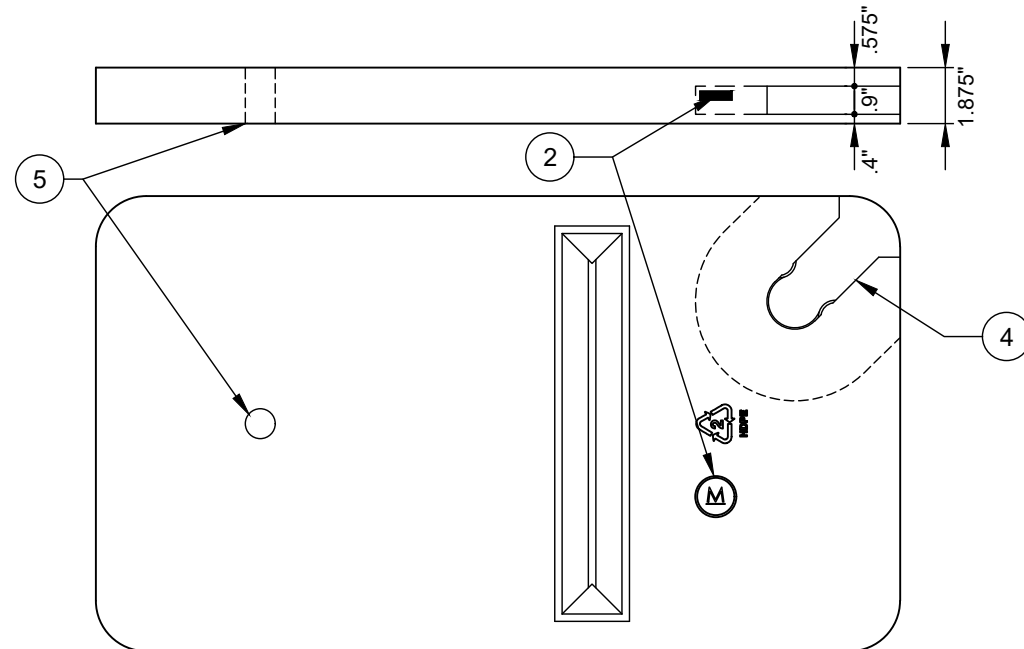
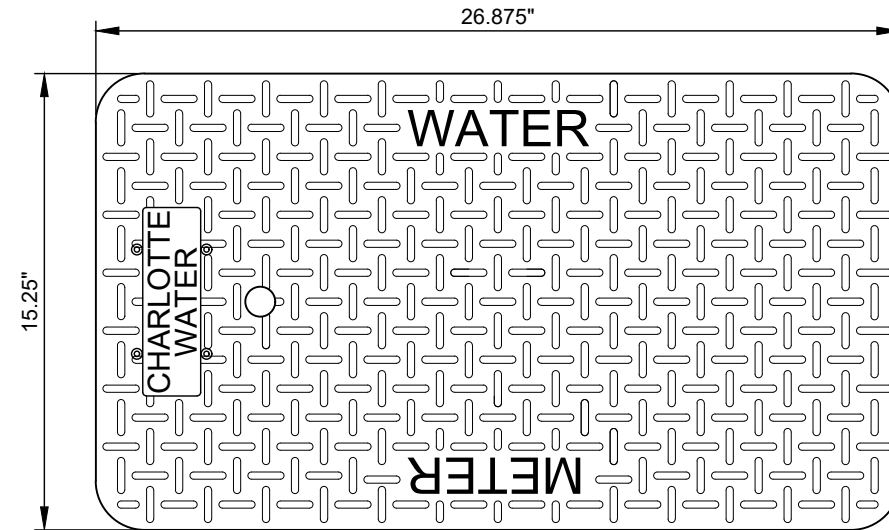

# DFW 65C - RSGSM - LID WEIGHT - LBS.

**NO. DESCRIPTION:**

1. 1/8" X Ø3/4" DIA. RARE EARTH MAGNET (MOLDED IN RARE EARTH MAGNET, MINIMUM 1.4 TESLA MAGNET STRENGTH).
2. 0.69" DIAMETER PICK HOLE.
3. MAGNET LOCATION MARKER.
4. ITRON 40W MOUNT.
5. 1" DIAMETER PICK HOLE.

**NOTES:**

- A. MATERIAL - HIGH DENSITY POLYETHYLENE (HDPE) - RECYCLED.
- B. COLOR - CHARLOTTE GREY.
- C. LOAD RATING - HEAVY DUTY.
- D. MANUFACTURER - SOUTHEASTERN DISTRIBUTORS, INC., DFW PLASTICS INC. OR APPROVED EQUAL.