

SHORT SIDE LATERAL SERVICE

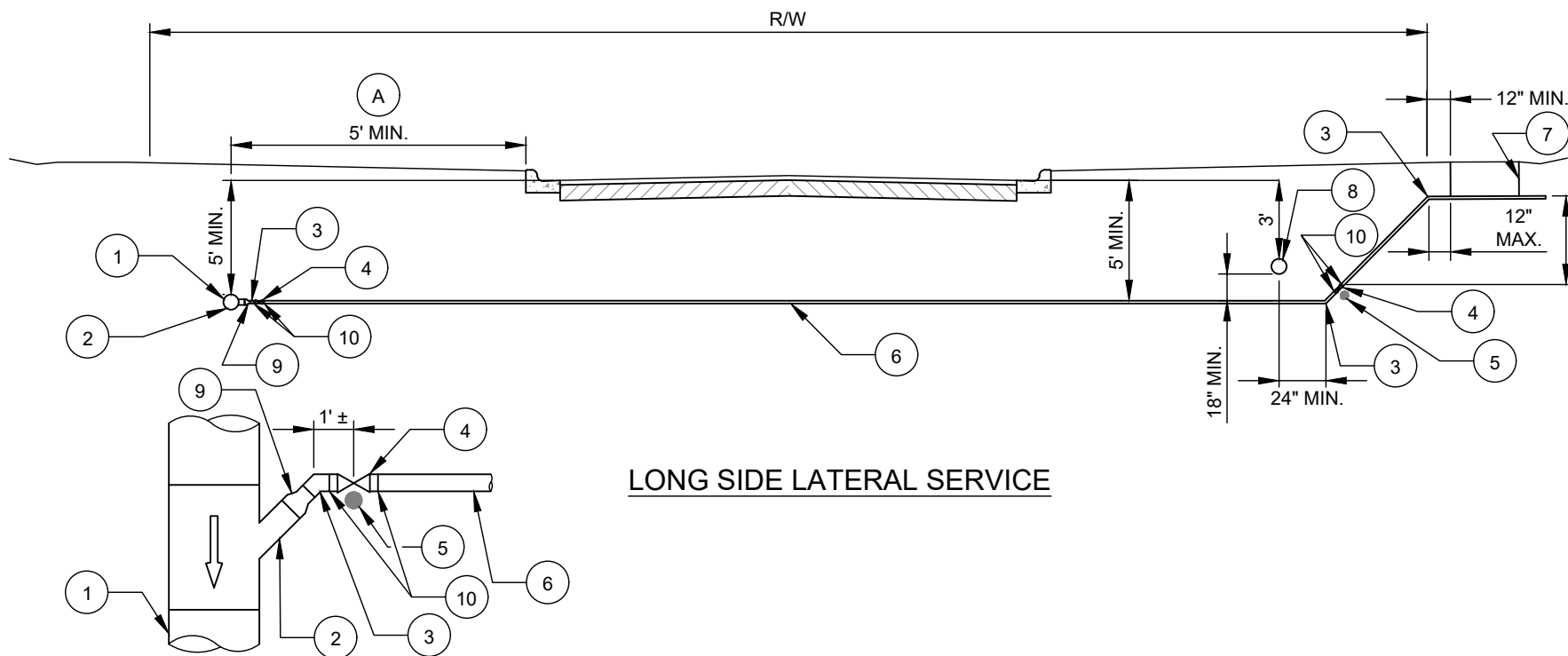

LONG SIDE LATERAL SERVICE

PLAN VIEW

NO. DESCRIPTION:

1. LOW PRESSURE SEWER MAIN (SDR 9 HDPE).
2. HORIZONTAL SERVICE WYE (SDR 9 HDPE).
3. 45° BEND (SDR 9 HDPE).
4. 1.5" TRUE UNION PVC BALL VALVE WITH THREADED END SOCKET (NO VALVE BOX ASSEMBLY).
5. PVC ENCAPSULATED MAGNET.
6. 1 1/2" SERVICE PIPE (SDR 9 HDPE).
7. SERVICE CONNECTION BOX.
8. WATER MAIN.
9. REDUCER (SDR 9 HDPE).
10. SDR 9 HDPE ADAPTOR WITH S.S. THREADED END.

NOTES:

- A. MINIMUM 5' FROM BOC AND OUTSIDE PLANTING STRIP. MUST MEET THE MOST STRINGENT GOVERNING AUTHORITY CRITERIA FOR MINIMUM SEPARATION FROM ALL OTHER UTILITIES.
- B. ALL H.D.P.E. PIPE AND FITTING JOINTS SHALL BE FUSED (SOCKET, BUTT OR ELECTROFUSED).
- C. USE OF MECHANICAL COUPLINGS IN THE H.D.P.E. PIPE SYSTEM ARE NOT PERMITTED WITHOUT SPECIFIC APPROVAL OF THE ENGINEER.
- D. TRACER WIRE NOT SHOWN FOR CLARITY. FOR TRACER WIRE INSTALLATION, REFER TO APPROPRIATE STANDARD DETAIL.