

U.S. FOUNDRY & MFG. CORP.

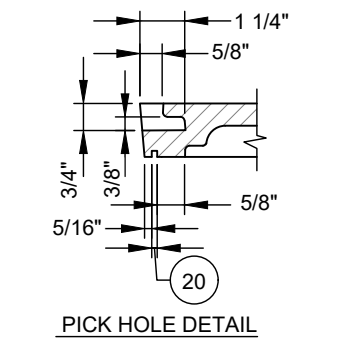

WEIGHT - 165 LB. MIN., 0% MINUS TOLERANCE  
MATERIAL - ASTM A48 CLASS 35 - CAST IRON

EJ (EJ GROUP, INC.)

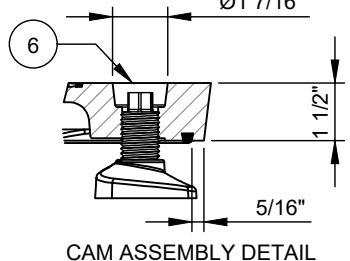
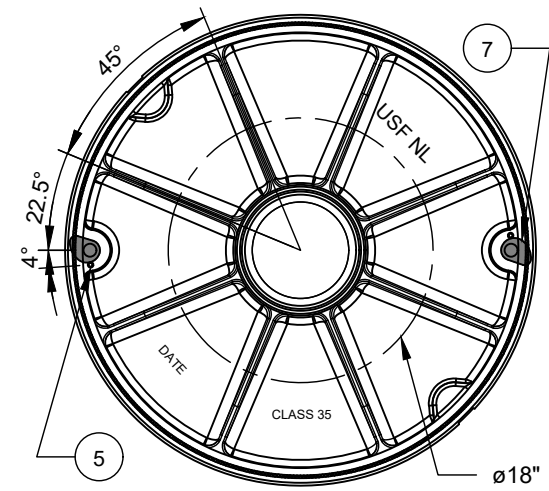
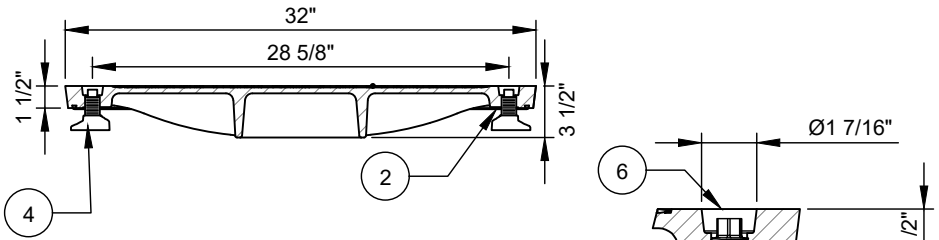
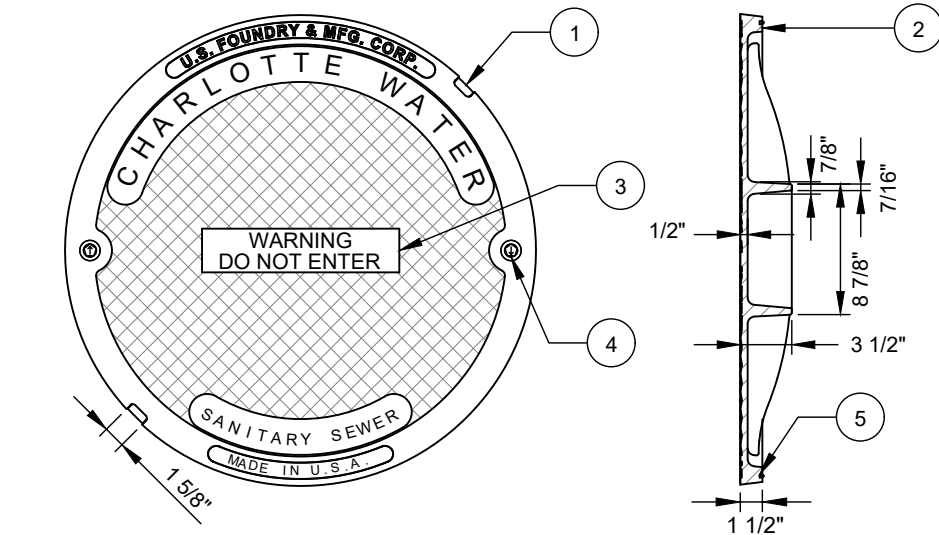
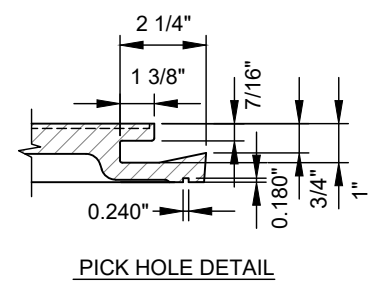
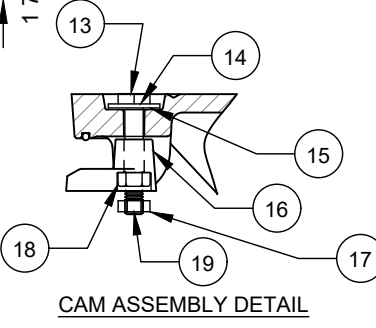
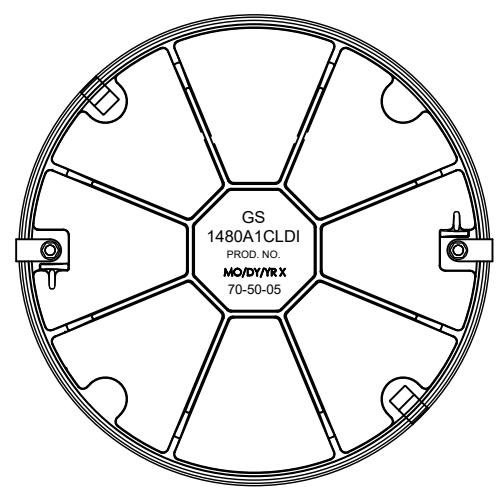
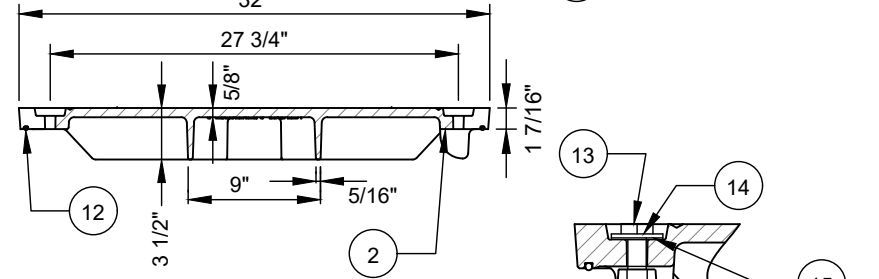
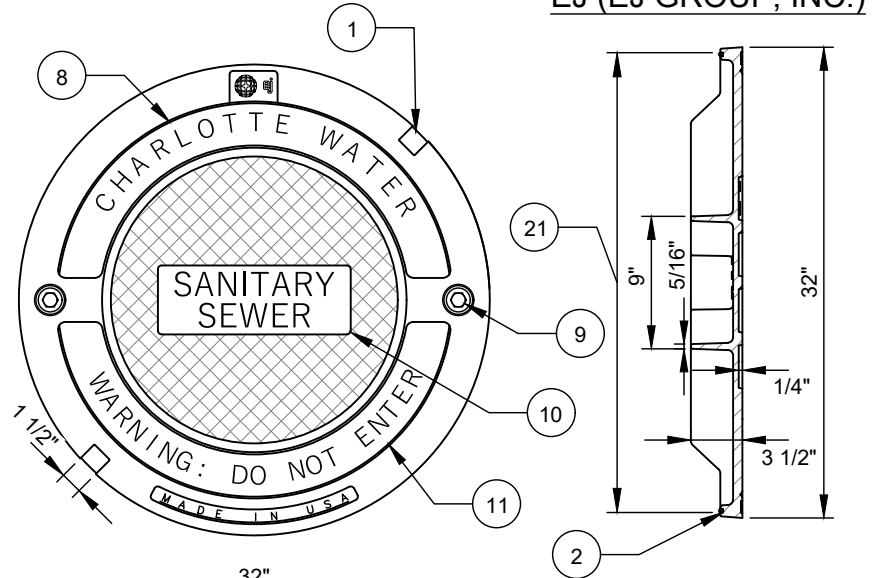

WEIGHT - 173 LB. MIN., 0% MINUS TOLERANCE  
MATERIAL - ASTM A536 DUCTILE IRON - GRADE 70-50-05

NO.	DESCRIPTION:
1.	(2)-NON PENETRATING PICKHOLES.
2.	MACHINED SURFACE.
3.	1 INCH ARIAL STYLE TEXT TYP.
4.	WEDGE CAM LOCK. SEE ASSEMBLY DETAIL.
5.	ORS GASKET NEOPRENE RUBBER 60 DUROMETER.
6.	USF WEDGE LOC 5/8" HEX HEAD BOLT ALL GRADE S.S. TYPE 304.
7.	7/8" DIAMETER CAM LOCK HOLE @ 28 5/8" DIAMETER.
8.	1 INCH SHARP FACE GOTHIC TEXT.
9.	(2) CAMS (SEE DETAIL).
10.	1 3/4" SHARP FACE GOTHIC TEXT.
11.	1 INCH SHARP FACE GOTHIC TEXT.
12.	1/4" NEOPRENE GASKET.
13.	5/8"-11 X 3 1/2" LG TYPE 304 SS HEX BOLT.
14.	5/8" I.D. 1 1/2" O.D. TYPE 304 SS FLAT WASHER.
15.	5/8" I.D. 1 1/2" O.D. SS FLAT WASHER AND RUBBER WASHER.
16.	BRONZE LOCK LUG.
17.	5/8" HEX JAM NUT TYPE 304 SS.
18.	5/8"-11 TYPE 304 SS NYLOK NUT.
19.	WELD ON JAM NUT OR PEEN END THREADS ON BOLT.
20.	3/16" DOVETAIL GROOVE.
21.	31 1/4" (OUTSIDE OF GROOVE).

NOTES:	
A.	LOAD RATING - HEAVY DUTY.
B.	MATERIAL - DUCTILE IRON OR CAST IRON AS INDICATED IN THE DETAIL.
C.	COATING - UNDIPPED.
D.	COVER SHALL CONFORM TO DIMENSION AND WEIGHT REQUIREMENTS.
E.	COVER SHALL NOT BE OUT OF ROUND.

CHARLOTTE WATER  
 A CITY OF CHARLOTTE DEPARTMENT  
 STANDARD DETAILS  
 GRAVITY SEWER  
 TYPE 5 MANHOLE COVER  
 30-INCHES DIAMETER (CLEAR OPENING)  
 WATERTIGHT - NO VENT HOLE, GASKET, CAM LOCK  
 NO SCALE  
 VERSION 1.0  
 DATE 04/2024  
 DETAIL 11.3.9