

U.S. FOUNDRY & MFG. CORP.

EJ (EJ GROUP, INC.)

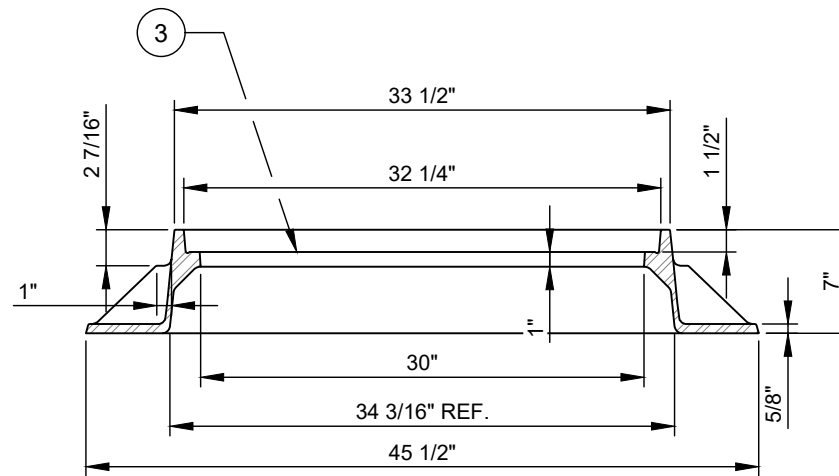
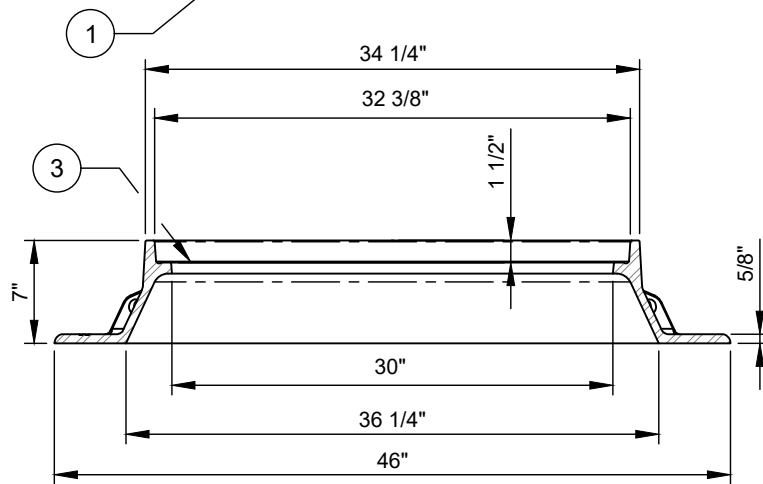
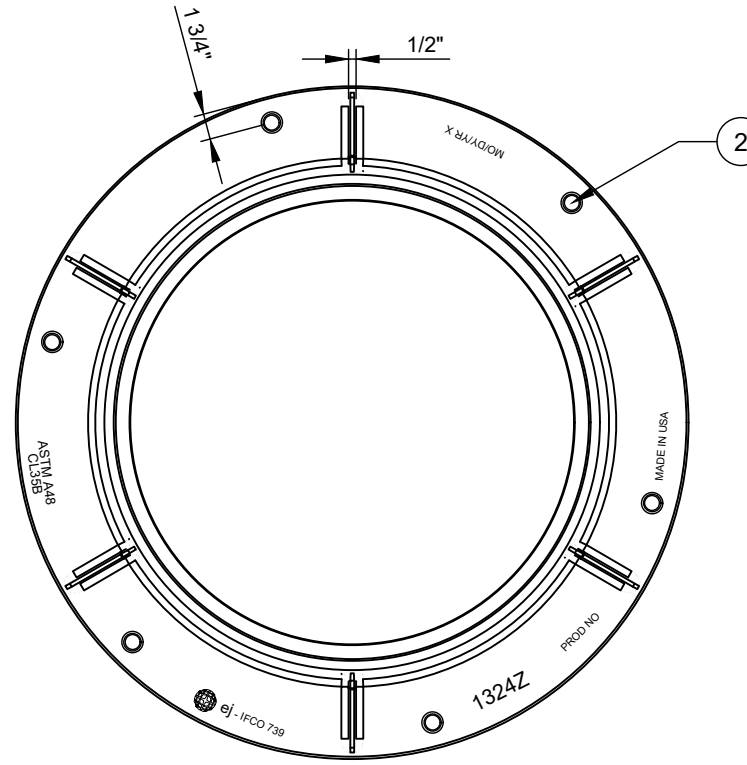
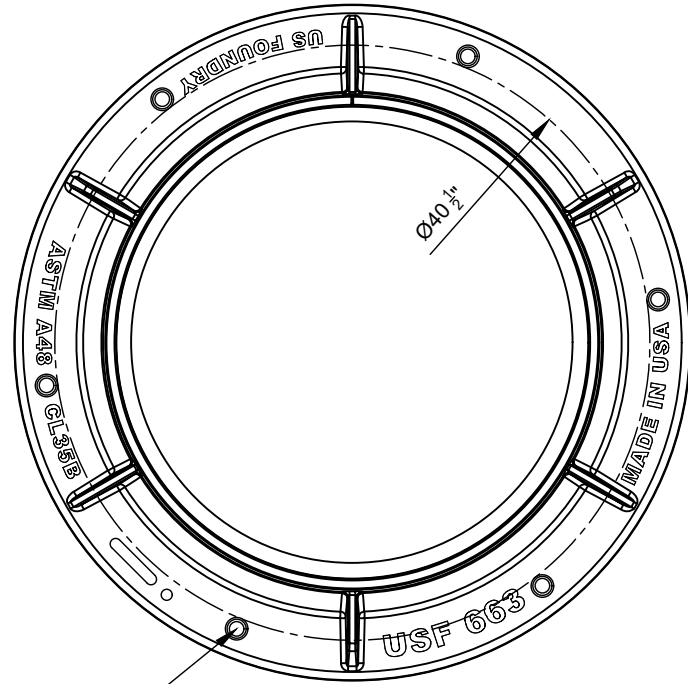

NO. DESCRIPTION:

1. (6) - 1 INCH DIAMETER THRU HOLES EQUALLY SPACED ON A 41" DIAMETER B.C.D.
2. (6) - 1 INCH DIAMETER THRU HOLES EQUALLY SPACED ON A 42" DIAMETER B.C.D.
3. MACHINED SURFACE.

NOTES:

- A. LOAD RATING - HEAVY DUTY.
- B. MATERIAL - ASTM A48 - CLASS 35 GRAY IRON.
- C. COATING - UNDIPPED.
- D. FRAME SHALL CONFORM TO DIMENSION AND WEIGHT REQUIREMENTS.
- E. FRAME SHALL NOT BE OUT OF ROUND.

WEIGHT - 320 LB. MIN., 0% MINUS TOLERANCE

WEIGHT - 270 LB. MIN., 0% MINUS TOLERANCE

CHARLOTTE WATER

CHARLOTTE WATER
A CITY OF CHARLOTTE DEPARTMENT
STANDARD DETAILS
GRAVITY SEWER

TYPE D MANHOLE FRAME
30-INCH DIAMETER (CLEAR OPENING)
7-INCHES TALL

NO SCALE

VERSION
1.0

DATE
04/2024

DETAIL
11.3.3