

U.S. FOUNDRY & MFG. CORP.

EJ (EJ GROUP, INC.)

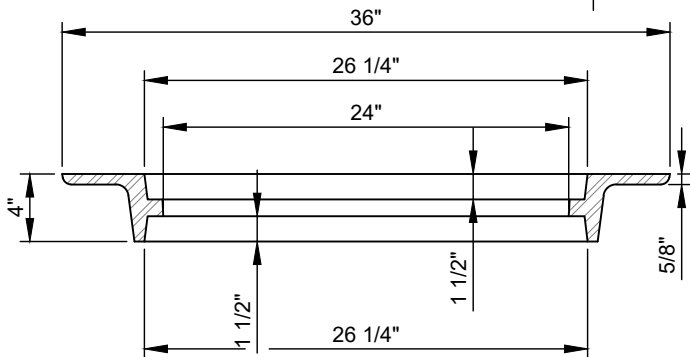

WEIGHT - 150 LB. MIN., 0% MINUS TOLERANCE

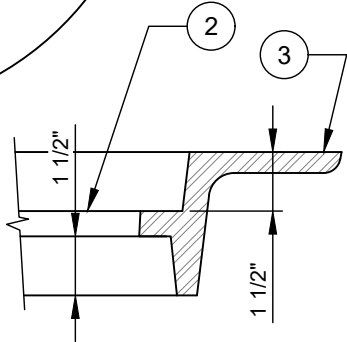
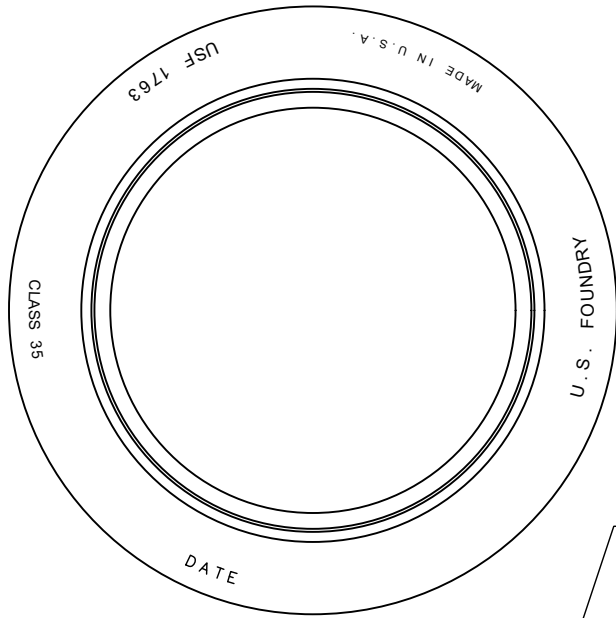
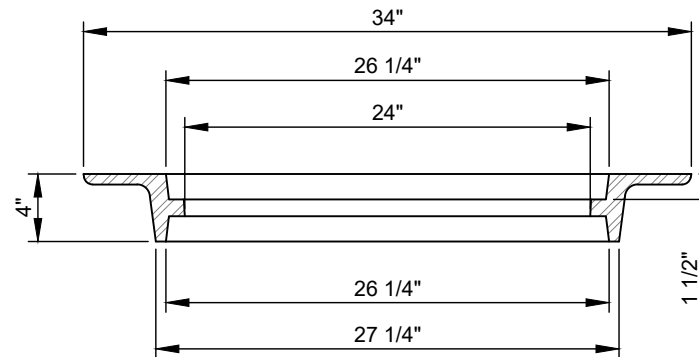
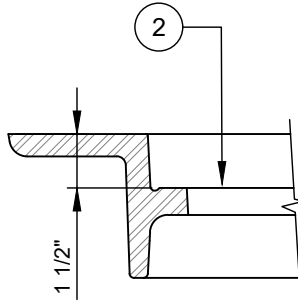
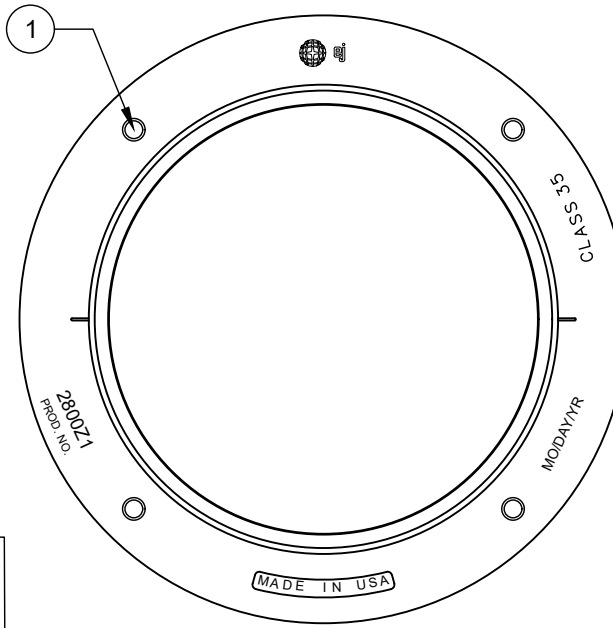

WEIGHT - 121 LB. MIN., 0% MINUS TOLERANCE

NO. DESCRIPTION:

1. (4) -1 INCH DIAMETER ANCHOR HOLES ON A 31" DIAMETER B.C.D.
2. MACHINED SURFACE.
3. FRAME.

NOTES:

- A. LOAD RATING - HEAVY DUTY.
- B. MATERIAL - ASTM A48 - CLASS 35 GRAY IRON.
- C. COATING - UNDIPPED.
- D. FRAME SHALL CONFORM TO DIMENSION AND WEIGHT REQUIREMENTS.
- E. FRAME SHALL NOT BE OUT OF ROUND.

CHARLOTTE WATER

A CITY OF CHARLOTTE DEPARTMENT
STANDARD DETAILS
GRAVITY SEWER

TYPE C MANHOLE FRAME
24-INCHES DIAMETER (CLEAR OPENING)
4-INCHES TALL - INVERTED (CAST IN)

NO SCALE

VERSION
1.0

DATE
04/2024

DETAIL
11.3.2