

U.S. FOUNDRY & MFG. CORP.

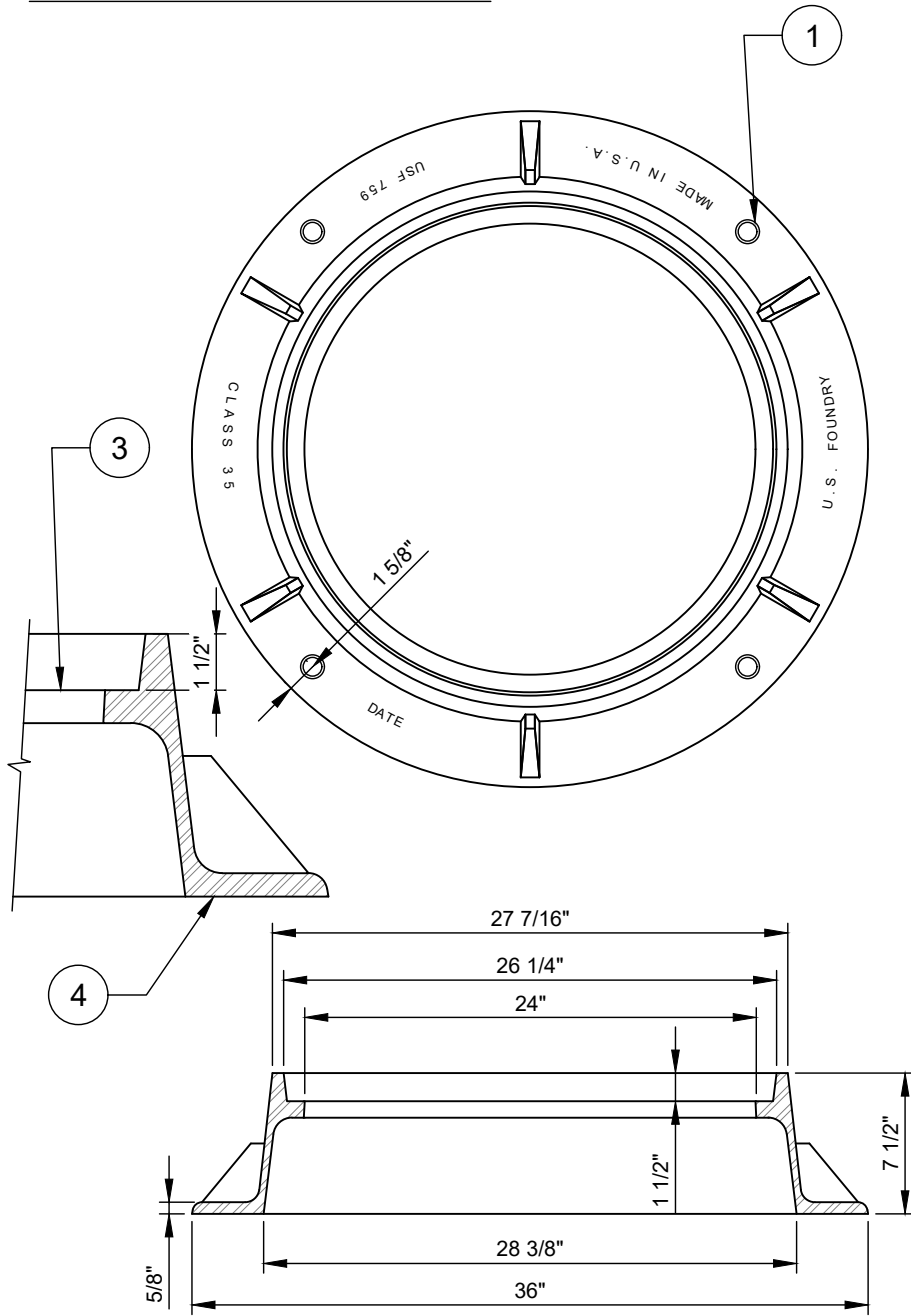

WEIGHT - 170 LB. MIN., 0% MINUS TOLERANCE

EJ (EJ GROUP, INC.)

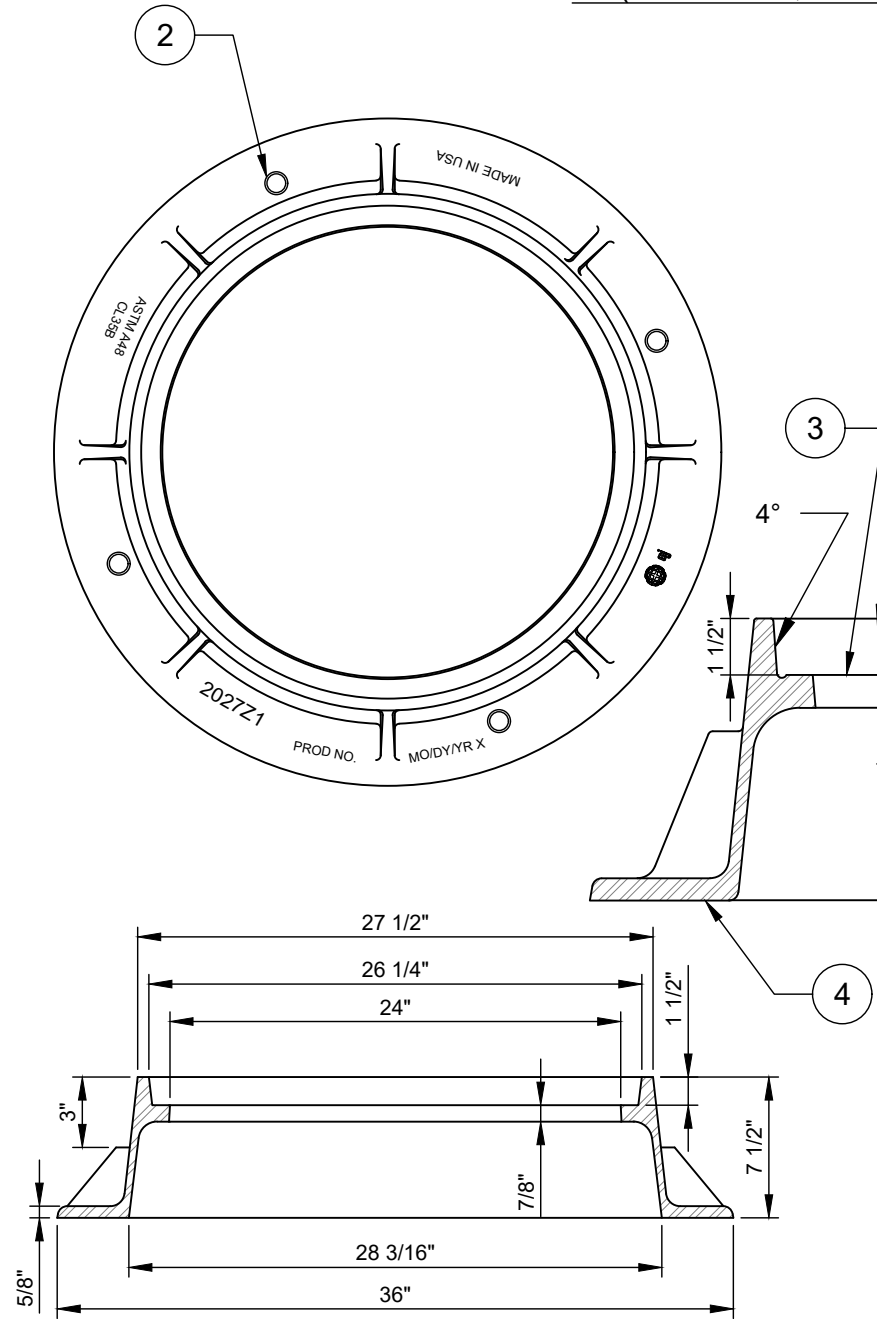

WEIGHT - 173 LB. MIN., 0% MINUS TOLERANCE

NO. DESCRIPTION:

1. (4) - 1 INCH DIAMETER ANCHOR HOLES ON A 32 3/4" DIAMETER B.C.D.
2. (4) - 1 INCH DIAMETER ANCHOR HOLES ON A 31" DIAMETER B.C.D.
3. MACHINED SURFACE.
4. FRAME.

NOTES:

- A. LOAD RATING - HEAVY DUTY.
- B. MATERIAL - ASTM A48 - CLASS 35 GRAY IRON.
- C. COATING - UNDIPPED.
- D. FRAME SHALL CONFORM TO DIMENSION AND WEIGHT REQUIREMENTS.
- E. FRAME SHALL NOT BE OUT OF ROUND.

CHARLOTTE  
WATER

CHARLOTTE WATER  
A CITY OF CHARLOTTE DEPARTMENT  
STANDARD DETAILS  
GRAVITY SEWER

TYPE A MANHOLE FRAME  
24-INCHES DIAMETER (CLEAR OPENING)  
7 1/2-INCHES TALL

NO SCALE

VERSION  
1.0

DATE  
04/2024

DETAIL  
11.3.1