

ROAD IN FILL SECTION

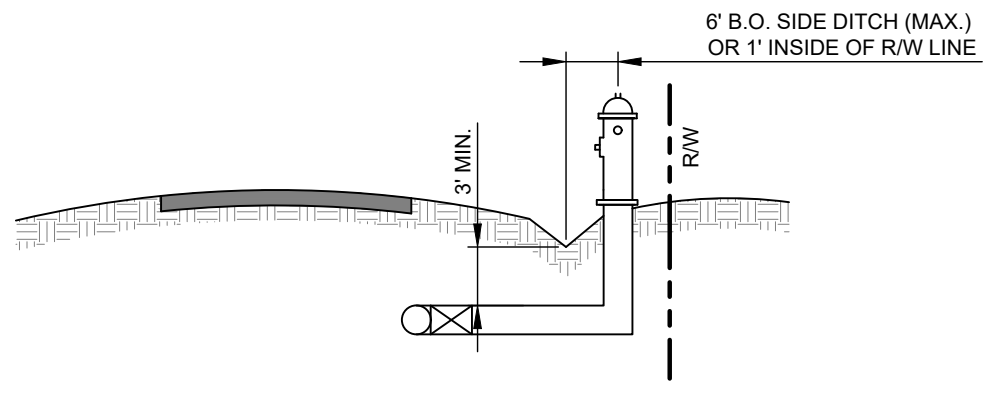

ROAD WITH SIDE DITCH

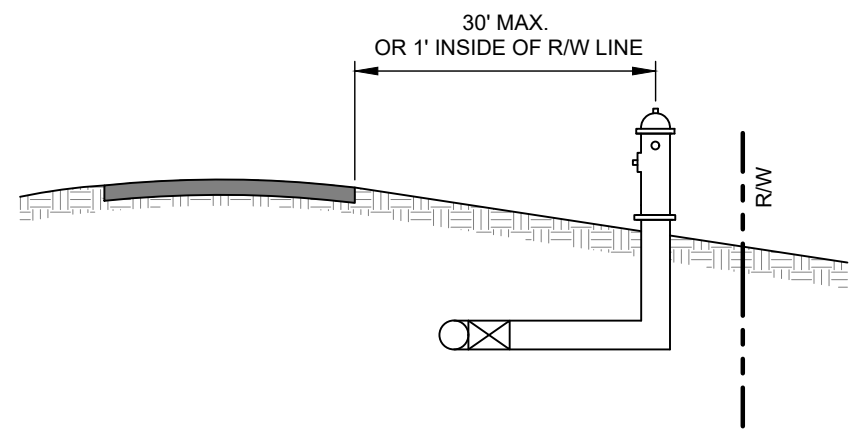

ROAD WITH NO SIDE DITCH

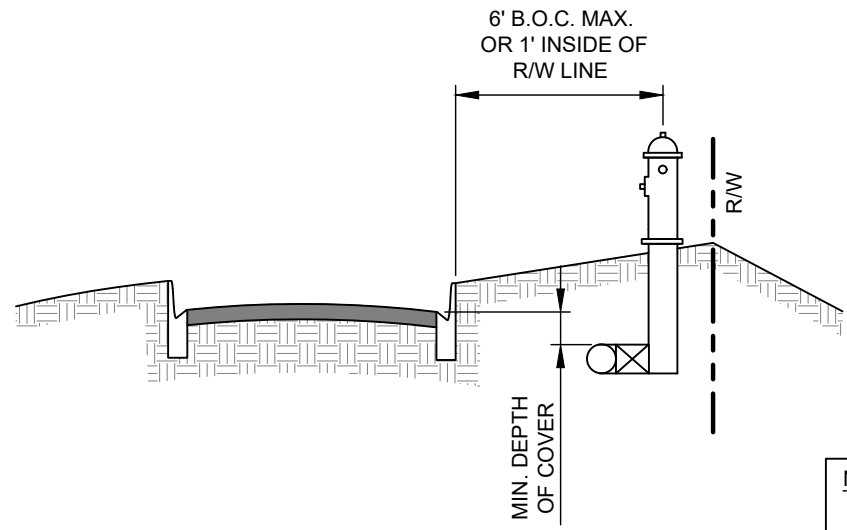

ROAD WITH CURB AND GUTTER

- NOTES:
- A. IN ALL CASES FIRE HYDRANT SHALL BE A MINIMUM OF 1' INSIDE ROAD R/W.
 - B. MAINLINE VALVES, GUARD VALVE, AND FIRE HYDRANT SHALL NOT BE PLACED IN DITCHLINE.
 - C. HYDRANT SHALL BE UNOBSTRUCTED.