

**NOTE:**  
A. AN ASTERIK (\*) SIGNIFIES THAT THE CALCULATED LENGTH WAS ROUNDED TO A FULL PIPE LENGTH JOINT FOR MINIMUM INSTALLATION.

NO.	DESCRIPTION:
1.	SLIP JOINT PIPE.
2.	RESTRAINED JOINT.
3.	RESTRAINED JOINT PIPE.
4.	RESTRAINED JOINT BEND.

DIP		VERTICAL OFFSET - L1 (FEET)							
		DIAMETER							
BEND ANGLE		6"	8"	10"	12"	16"	20"	24"	
	L1	L1	L1	L1	L1	L1	L1	L1	
45		140	181	218	256	256	309	299	
22.5		67	87	105	123	122	148	144	
11.25		36*	54*	54*	61	61	73	71	

POLYWRAPPED DIP/PVC		VERTICAL OFFSET - L1 (FEET)							
		DIAMETER							
BEND ANGLE		6"	8"	10"	12"	16"	20"	24"	
	L1	L1	L1	L1	L1	L1	L1	L1	
45		200	259	312	365	364	441	427	
22.5		96	124	150	175	175	212	205	
11.25		54*	62	74	87	87	105	102	

DIP		VERTICAL OFFSET - L2 (FEET)							
		DIAMETER							
BEND ANGLE		6"	8"	10"	12"	16"	20"	24"	
	L2	L2	L2	L2	L2	L2	L2	L2	
45		90	116	139	163	162	195	189	
22.5		54*	56	67	78	78	94	91	
11.25		36*	36*	36*	54*	54*	54*	54	

POLYWRAPPED DIP/PVC		VERTICAL OFFSET - L2 (FEET)							
		DIAMETER							
BEND ANGLE		6"	8"	10"	12"	16"	20"	24"	
	L2	L2	L2	L2	L2	L2	L2	L2	
45		112	144	173	201	200	241	233	
22.5		54*	69	83	97	96	116	112	
11.25		36*	36*	54*	54*	54*	57	55	

**DESIGN BASIS:**  
DIPRA "THRUST RESTRAINT DESIGN FOR DIP"  
LAYING CONDITION: TYPE 2  
SOIL DESIGNATION: SILT 1  
DEPTH OF COVER: 3' MINIMUM (SEE NOTE c)  
DESIGN PRESSURE: 200 PSI  
SAFETY FACTOR: 2.0

**NOTES:**  
a. 12" AND SMALLER DIP MAY BE SLIP JOINT PIPE WITH GRIP RESTRAINT GASKETS.  
b. 16" AND LARGER DIP SHALL BE FACTORY RESTRAINT JOINT PIPE AND FITTINGS.  
c. DEPTH OF COVER FOR 16" AND 20" PIPE IS 4' AND FOR 24" PIPE IS 5'.  
d. DESIGN ENGINEER CAN SUBMIT ALTERNATIVE DESIGN BASIS FOR RESTRAINED JOINT LENGTH CALCULATIONS FOR OWNER REVIEW.

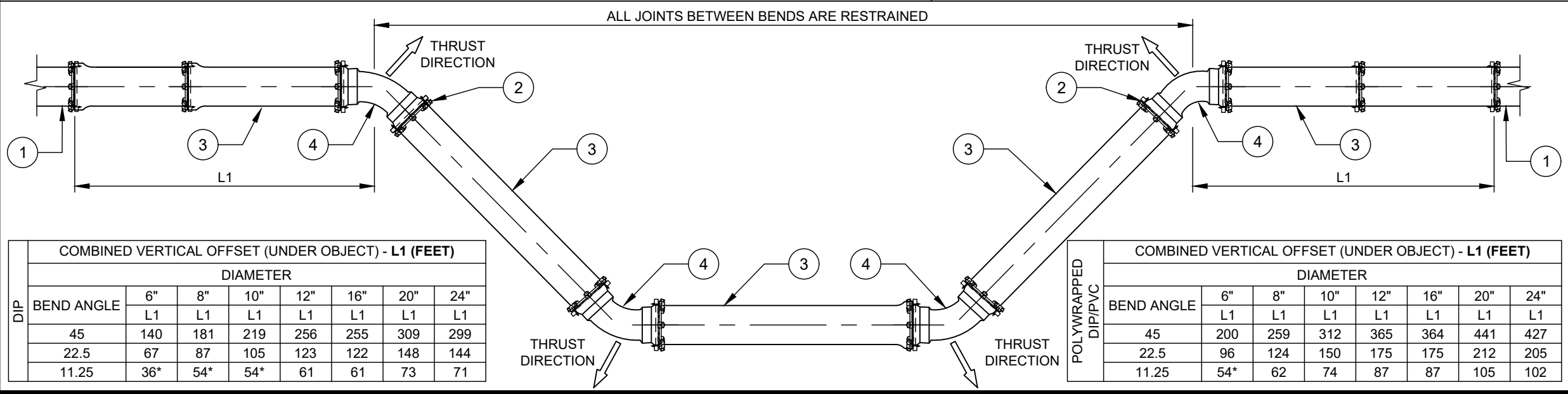

DIP		COMBINED VERTICAL OFFSET (UNDER OBJECT) - L1 (FEET)							
		DIAMETER							
BEND ANGLE		6"	8"	10"	12"	16"	20"	24"	
	L1	L1	L1	L1	L1	L1	L1	L1	
45		140	181	219	256	255	309	299	
22.5		67	87	105	123	122	148	144	
11.25		36*	54*	54*	61	61	73	71	

POLYWRAPPED DIP/PVC		COMBINED VERTICAL OFFSET (UNDER OBJECT) - L1 (FEET)							
		DIAMETER							
BEND ANGLE		6"	8"	10"	12"	16"	20"	24"	
	L1	L1	L1	L1	L1	L1	L1	L1	
45		200	259	312	365	364	441	427	
22.5		96	124	150	175	175	212	205	
11.25		54*	62	74	87	87	105	102	