

TYPE A
USING CAST IRON SOIL PIPE

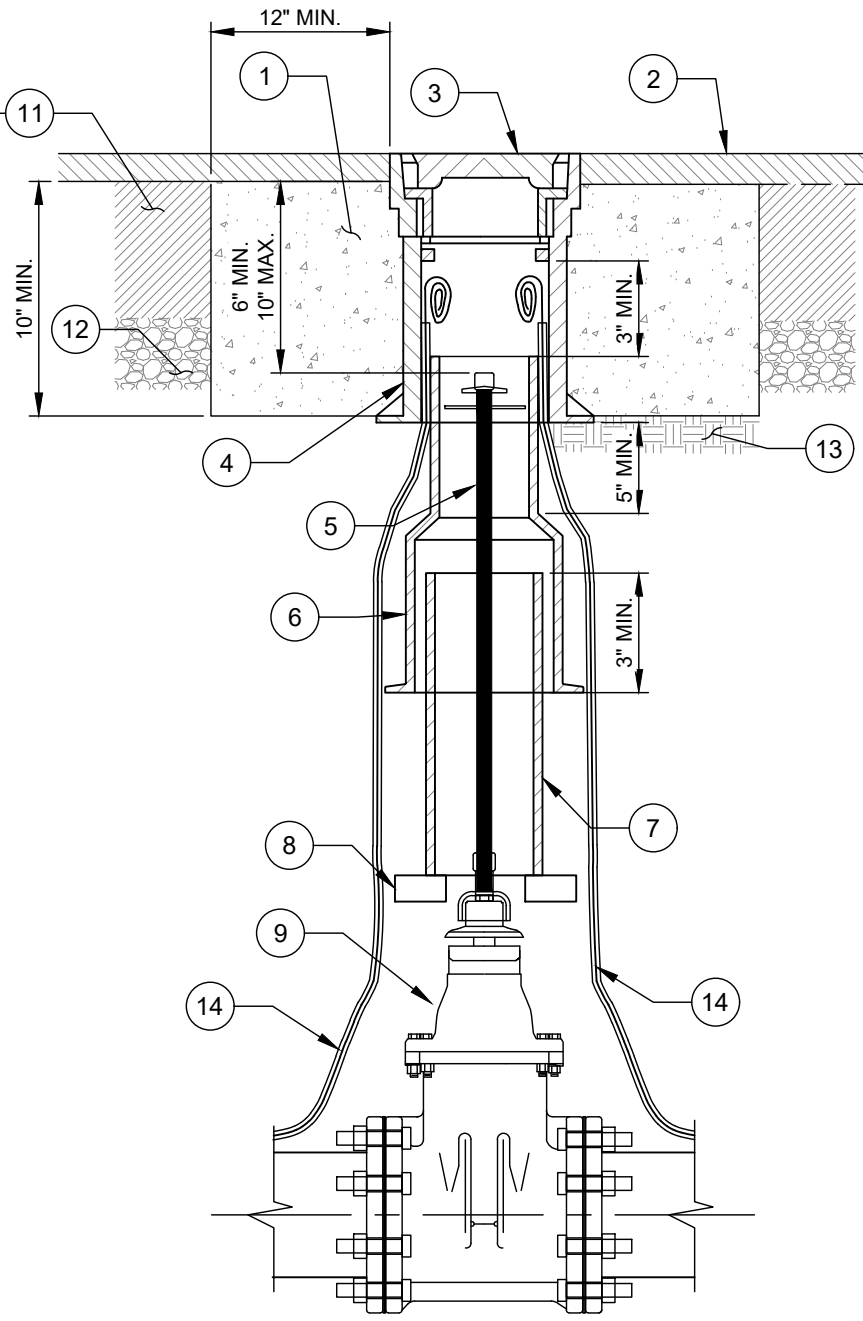

TYPE B
USING PVC PIPE

NO. DESCRIPTION:

1. CONCRETE PAD - CAST IN PLACE.
2. FINAL ASPHALT SURFACE COURSE.
3. VALVE BOX COVER.
4. TOP SECTION VALVE BOX.
5. EXTENSION STEM AS REQUIRED.
6. BOTTOM SECTION VALVE BOX.
7. 6" PVC PIPE (C900 OR SDR26).
8. STANDARD CONCRETE BRICK - 2 EACH.
9. GATE VALVE (OR BALL VALVE, AS APPLICABLE).
10. 5" DIAMETER CAST IRON SOIL PIPE - BELL OF PIPE WILL RECEIVE BOTTOM SECTION OF VALVE BOX.
11. EXISTING OR NEW PAVEMENT.
12. COMPACTED AGGREGATE BASE COURSE (CABC).
13. COMPACTED SUBGRADE.
14. AWG #12 GAUGE SOLID COPPER HDPE TRACER WIRE WITH 30 MILS HDPE BLUE INSULATION, TERMINATE WITH 24" EXCESS WIRE (COILED) AT METER BOX AND VALVE BOX (TYP.).

NOTES:

- A. WATER VALVE ADJUSTMENTS WILL BE COMPLETED AT LEAST 36 HOURS BEFORE RESURFACING.
- B. 12" MINIMUM WIDTH OF EXCAVATION AROUND VALVE BOX.
- C. DISTURBED AREAS AROUND STRUCTURE ADJUSTMENTS ARE TO BE TAMPED AND FILLED WITH 4,000 PSI "HIGH EARLY" PORTLAND CEMENT CONCRETE.
- D. ALL DAMAGED OR MISALIGNED VALVE BOXES ARE TO BE REPORTED TO INSPECTOR, OTHERWISE CONTRACTOR ASSUMES RESPONSIBILITY FOR DAMAGE OR MISALIGNMENT.
- E. IF THE VERTICAL ADJUSTMENT CAUSES LESS THAN ONE INCH OVERLAP BETWEEN TOP SECTION AND RISER PIPE, CONTRACTOR WILL REMOVE AND REPLACE RISER PIPE FROM BOTTOM SECTION TO TOP TO PROVIDE 3" OF OVERLAP IN TOP SECTION FOR TYPE A OR IF THE VERTICAL ADJUSTMENT CAUSES LESS THAN ONE INCH OVERLAP BETWEEN TOP SECTION AND BOTTOM SECTION, CONTRACTOR WILL REMOVE AND RESET BOTTOM SECTION TO PROVIDE A MINIMUM OF 3" OVERLAP AT TOP SECTION/BOTTOM SECTION JOINT SECTION & BOTTOM SECTION/RISER PIPE JOINT FOR TYPE B.
- F. ALL CONCRETE SHALL BE VIBRATED IN ACCORDANCE WITH N.C. DEPARTMENT OF TRANSPORTATION SPECIFICATIONS.
- G. TOP & BOTTOM SECTION TO BE CENTERED OVER NUT, NOT TO BEAR ON VALVE BODY.
- H. PROVIDE CLEARANCE BETWEEN VALVE BOX/BRICK AND THE VALVE.
- I. VALVE BOX ASSEMBLY SHALL CONSIST OF NO MORE THAN 3 VERTICAL SECTIONS - 1 TOP SECTION, 1 - BOTTOM SECTION AND 1 - PIPE RISER SECTION.

CHARLOTTE WATER A CITY OF CHARLOTTE DEPARTMENT STANDARD DETAILS WATER
VERTICAL VALVE BOX ADJUSTMENT FOR PAVEMENT RESURFACING
NO SCALE VERSION 1.0 DATE 04/2024 DETAIL 10.1.2