

ELEVATION VIEW

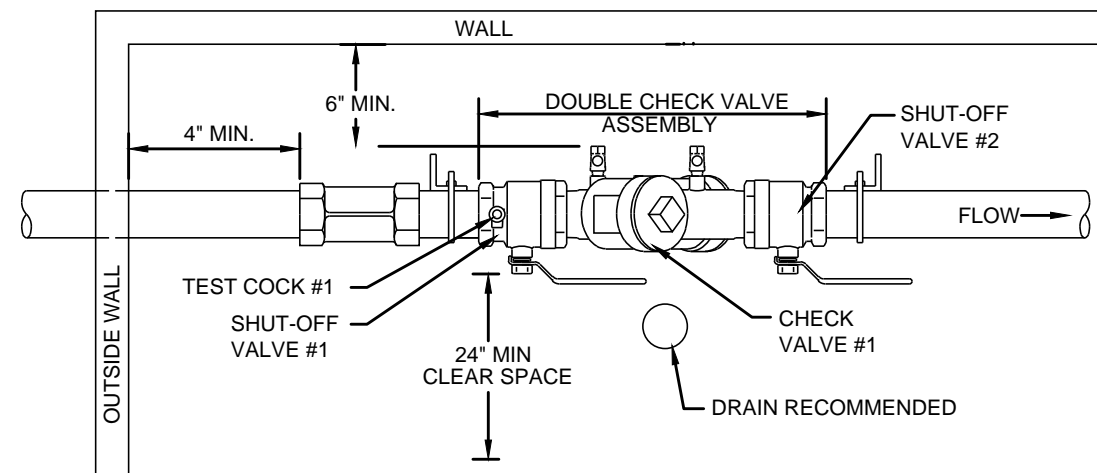

PLAN VIEW

NOTES:

1. INDOOR INSTALLATION SHALL ONLY BE PERMITTED IN CASES WHERE ADEQUATE SPACE FOR THE BACKFLOW PREVENTION ASSEMBLY IS NOT AVAILABLE OUTSIDE. CLT WATER WILL REVIEW ON A CASE BY CASE BASIS.
2. BACKFLOW PREVENTION ASSEMBLIES (BPA's) SHALL CONFORM TO CLT WATER SPECIFICATIONS. SHUT-OFF VALVES ARE SPECIFIC TO EACH APPROVED BPA AND NO SUBSTITUTIONS OF SHUT-OFF VALVES ARE PERMITTED. REFER TO CLT WATER APPROVED LIST OF BPA's.
3. ASSEMBLIES SHALL BE INSTALLED UPRIGHT AND IN THE HORIZONTAL POSITION.
4. PIPE MATERIAL AND FITTINGS SHALL BE AS SPECIFIED IN CLT WATER STANDARDS & SPECIFICATIONS.
5. SUPPORT FOR ASSEMBLY SHALL BE DESIGNED BY OWNER AS REQUIRED.
6. ALL LOCATIONS FOR BPA'S REQUIRE CLT WATER APPROVAL.
7. THERE SHALL BE NO TAPS, PIPING BRANCHES, UNAPPROVED BYPASS PIPING, HYDRANTS, FIRE DEPT. CONNECTION POINTS, OR OTHER WATER - USING APPURTENANCES CONNECTED TO THE SUPPLY LINE BETWEEN ANY WATER METER AND ITS CLT WATER - REQUIRED BACKFLOW PREVENTER.
8. EACH CLT WATER-REQUIRED BPA IS REQUIRED TO BE TESTED BY A CLT WATER - APPROVED CERTIFIED TESTER PRIOR TO PLACING THE WATER SYSTEM IN SERVICE. TEST RESULTS SHALL BE SUBMITTED TO CLT WATER WITHIN 30 DAYS AND TESTED ANNUALLY THEREAFTER SUBMITTING RESULTS TO CLT WATER.
9. ALL INSTALLATIONS INTENDED FOR ADDRESSING CLT WATER REQUIREMENTS, REQUIRE PRIOR APPROVAL FROM THE APPROPRIATE CLT WATER BACKFLOW INSPECTOR.

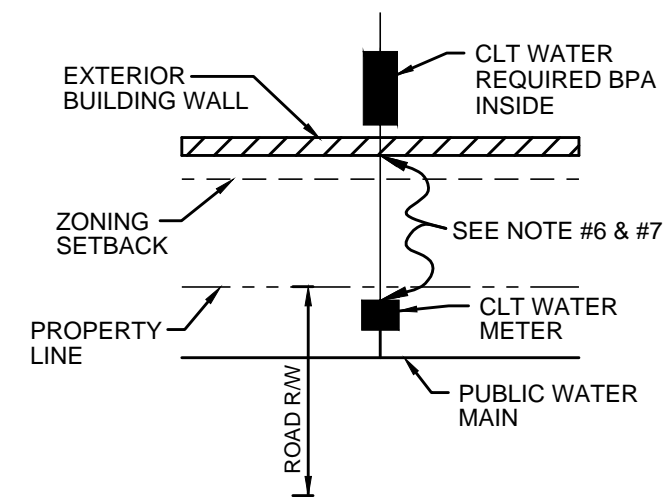

TYPICAL LOCATION REQUIREMENT FOR INSIDE INSTALLATION  
N.T.S.

NO SCALE

STANDARD NO. 10

VERSION NO. 1.1

VERSION DATE 5.3.2016

DOUBLE CHECK VALVE ASSEMBLY (DC)

3/4" - 2"-INDOOR

CHARLOTTE WATER  
STANDARD DETAILS  
BACKFLOW PREVENTION

CHARLOTTE WATER

A CITY OF CHARLOTTE DEPARTMENT