

ELEVATION VIEW

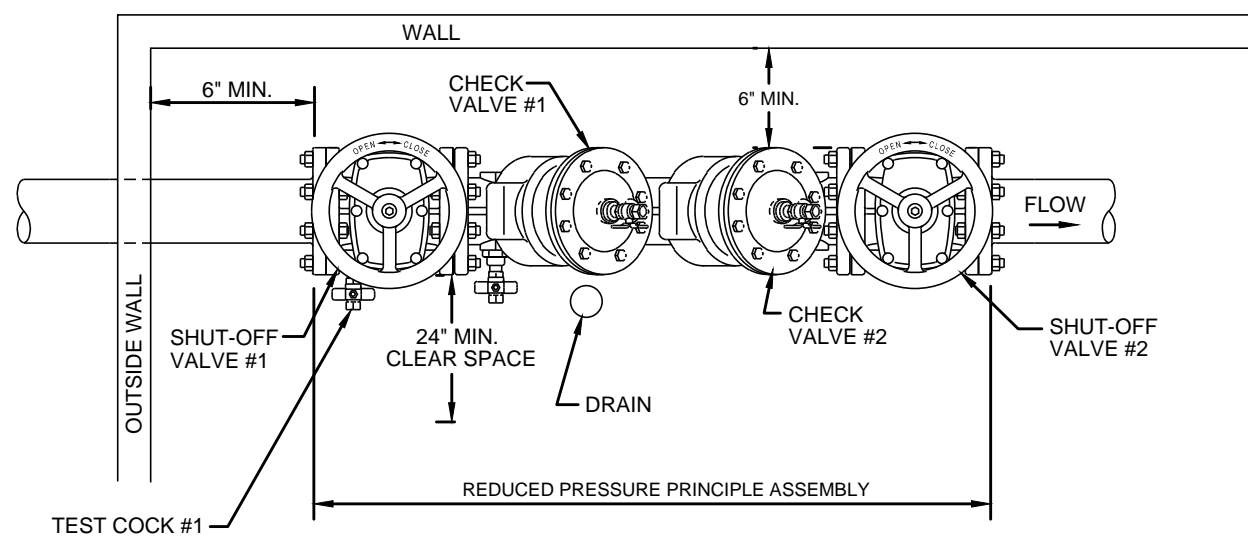

PLAN VIEW

NOTES:

1. INDOOR INSTALLATION SHALL ONLY BE PERMITTED IN CASES WHERE ADEQUATE SPACE FOR THE BACKFLOW PREVENTION ASSEMBLY IS NOT AVAILABLE OUTSIDE. CLT WATER WILL REVIEW ON A CASE BY CASE BASIC.
2. BACKFLOW PREVENTION ASSEMBLIES (BPA'S) SHALL CONFORM TO CLT WATER SPECIFICATIONS. SHUT-OFF VALVES ARE SPECIFIC TO EACH APPROVED BPA AND NO SUBSTITUTIONS OF SHUT-OFF VALVES ARE PERMITTED. REFER TO CLT WATER APPROVED LIST OF BPA'S.
3. FIRE LINE INSTALLATIONS SHALL HAVE OUTSIDE STEM AND YOKE (OS&Y) HANDWHEEL OPERATORS OR BUTTERFLY VALVES, AND LISTED ON APPROVED LIST AS FIRE APPROVED. IF SERVING FIRE SPRINKLERS, TAMPER SWITCHES ARE REQUIRED.
4. ASSEMBLIES SHALL BE INSTALLED UPRIGHT AND IN THE HORIZONTAL POSITION.
5. PIPE MATERIAL AND FITTINGS SHALL BE AS SPECIFIED IN CLT WATER STANDARDS & SPECIFICATIONS.
6. SUPPORT FOR ASSEMBLY SHALL BE DESIGNED BY OWNER, 8" - 12" SHALL BE SUPPORTED AT EACH VALVE AND SHALL NOT BLOCK RELIEF VALVE ON DRAIN PORT.
7. AN AIR GAP DRAIN IS RECOMMENDED TO REDUCE SPLASHING OF MINOR DISCHARGES FROM THE RELIEF VALVE DRAIN PORT.
8. INDOOR INSTALLATION OF RP'S SHOULD PROVIDE FOR DRAINAGE CAPABLE OF HANDLING IN EXCESS OF THE MAXIMUM DISCHARGE RATE EXPECTED BY THE BACKFLOW ASSEMBLY MANUFACTURER.
9. ALL LOCATIONS FOR BPA'S REQUIRE CLT WATER APPROVAL.
10. THERE SHALL BE NO TAPS, PIPING BRANCHES, UNAPPROVED BYPASS PIPING, HYDRANTS, FIRE DEPT. CONNECTION POINTS, OR OTHER WATER - USING APPURTENANCES CONNECTED TO THE SUPPLY LINE BETWEEN ANY WATER METER AND ITS CLT WATER - REQUIRED BACKFLOW PREVENTER.
11. EACH CLT WATER-REQUIRED BPA IS REQUIRED TO BE TESTED BY A CLT WATER - APPROVED CERTIFIED TESTER PRIOR TO PLACING THE WATER SYSTEM IN SERVICE. TEST RESULTS SHALL BE SUBMITTED TO CLT WATER WITHIN 30 DAYS AND TESTED ANNUALLY THEREAFTER SUBMITTING RESULTS TO CLT WATER.
12. ALL INSTALLATIONS INTENDED FOR ADDRESSING CLT WATER REQUIREMENTS, REQUIRE PRIOR APPROVAL FROM THE APPROPRIATE CLT WATER BACKFLOW INSPECTOR.

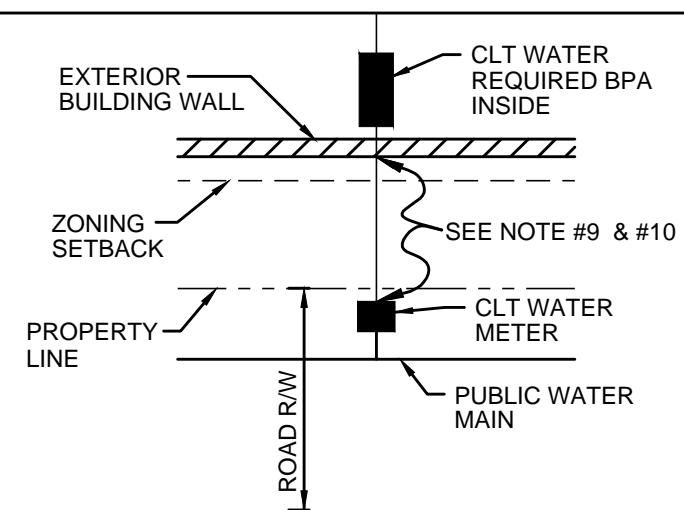

TYPICAL LOCATION REQUIREMENT FOR INSIDE INSTALLATION
N.T.S.

NO SCALE

STANDARD NO.	9	VERSION DATE	5.3.2016
VERSION NO.	1.2		

REDUCED PRESSURE PRINCIPLE ASSEMBLY (RP) 2 1/2" - 12" INDOOR

CHARLOTTE WATER
STANDARD DETAILS
BACKFLOW PREVENTION