

U.S. FOUNDRY & MFG. CORP.

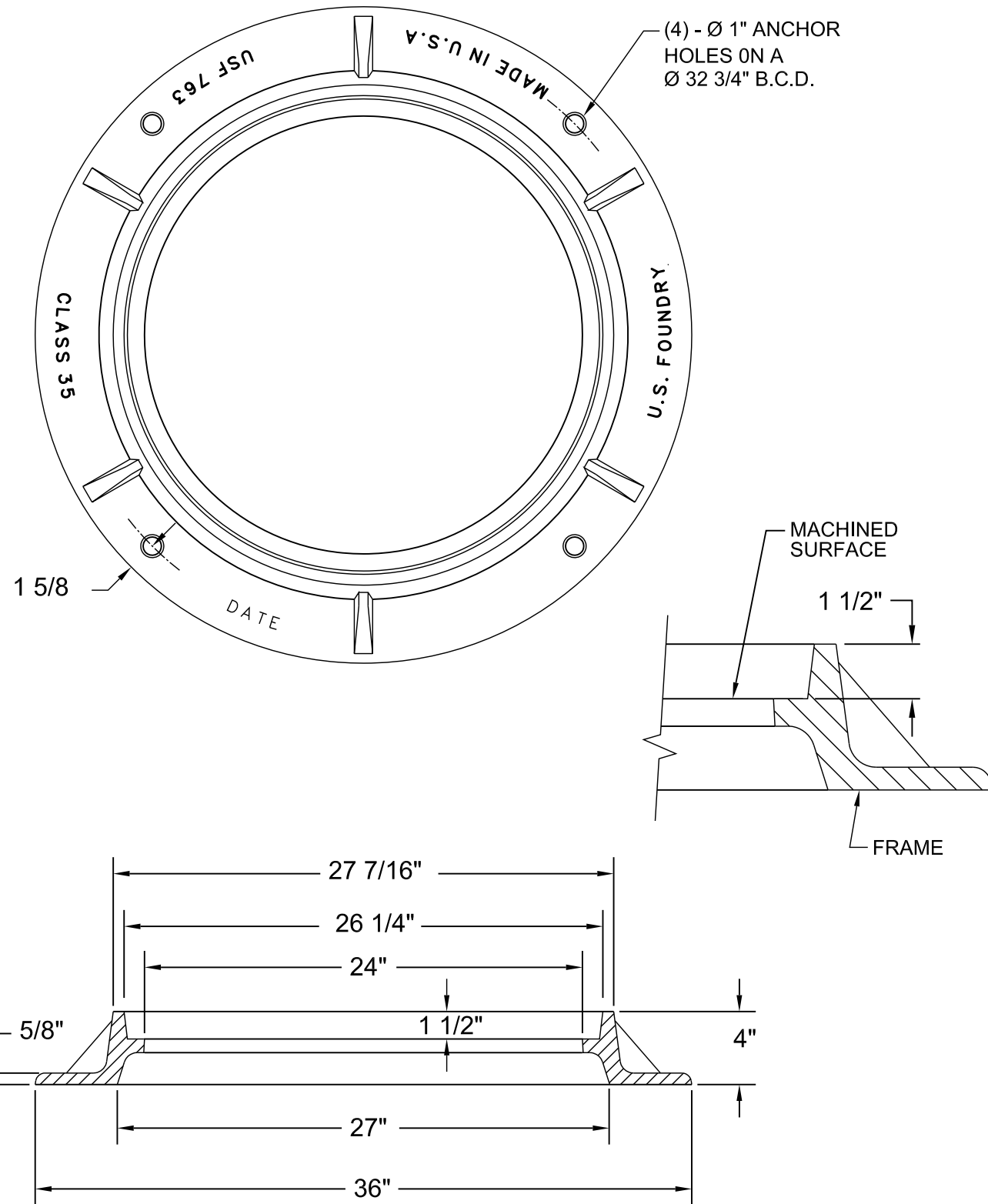

WEIGHT - 155 LB. MIN. , 0% MINUS TOLERANCE

NOTES:

LOAD RATING - HEAVY DUTY
 MATERIAL - ASTM A48 - CLASS 35 GRAY IRON
 COATING - UNDIPPED

EAST JORDAN IRON WORKS

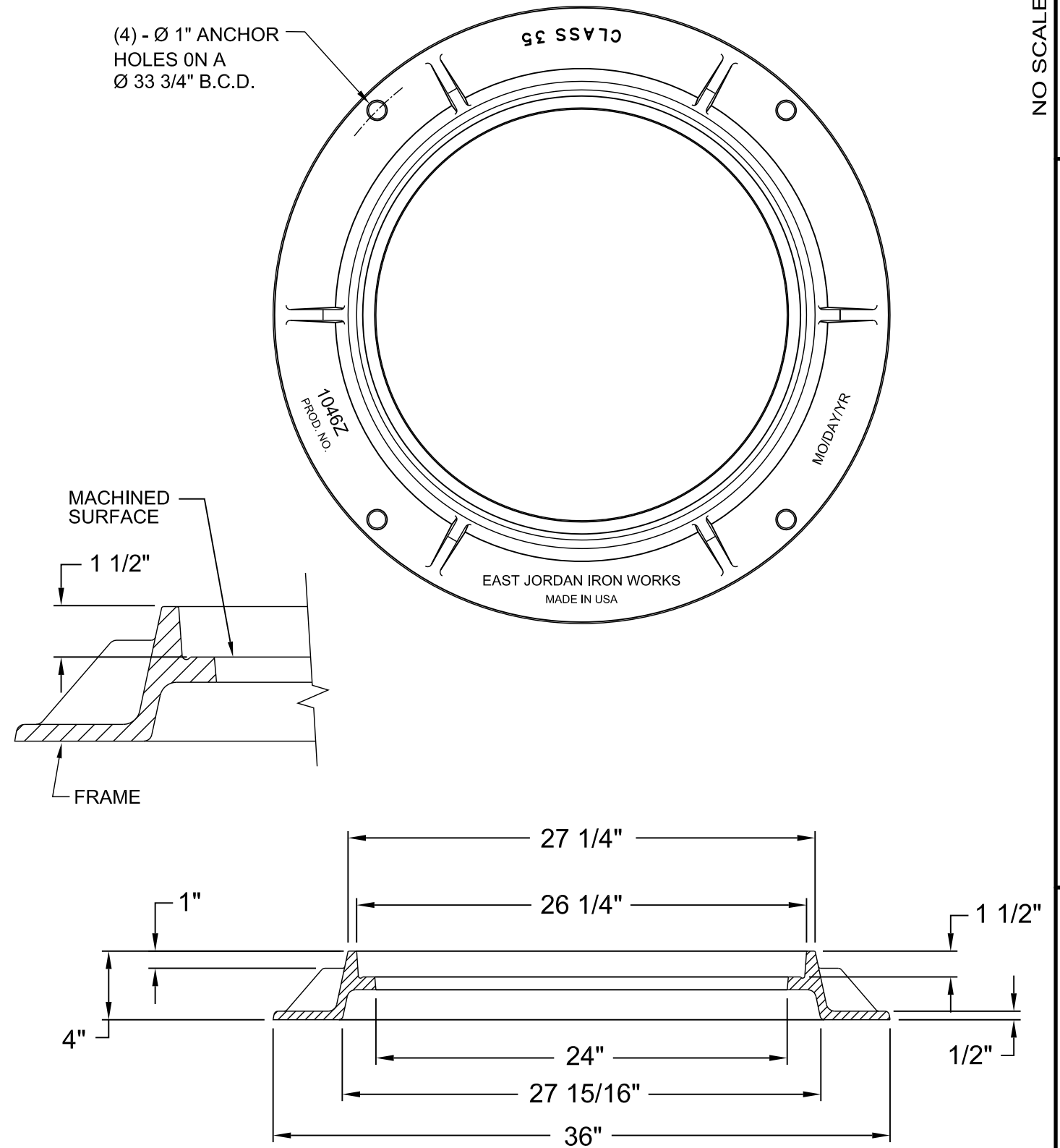

WEIGHT - 135 LB. MIN. , 0% MINUS TOLERANCE

STANDARD NO.	G
VERSION NO.	V1.1
VERSION DATE	8.18.2009

NO SCALE

TYPE B MANHOLE FRAME
 24-INCHES DIAMETER (CLEAR OPENING)
 4-INCHES TALL

CHARLOTTE-MECKLENBURG UTILITIES
 STANDARD DETAILS
 GRAVITY SEWER



USE WITH TYPE 1, 2, OR 3 COVER
 FRAME SHALL CONFORM TO DIMENSION AND WEIGHT REQUIREMENTS.
 FRAME SHALL NOT BE OUT OF ROUND.