

U.S. FOUNDRY & MFG. CORP.

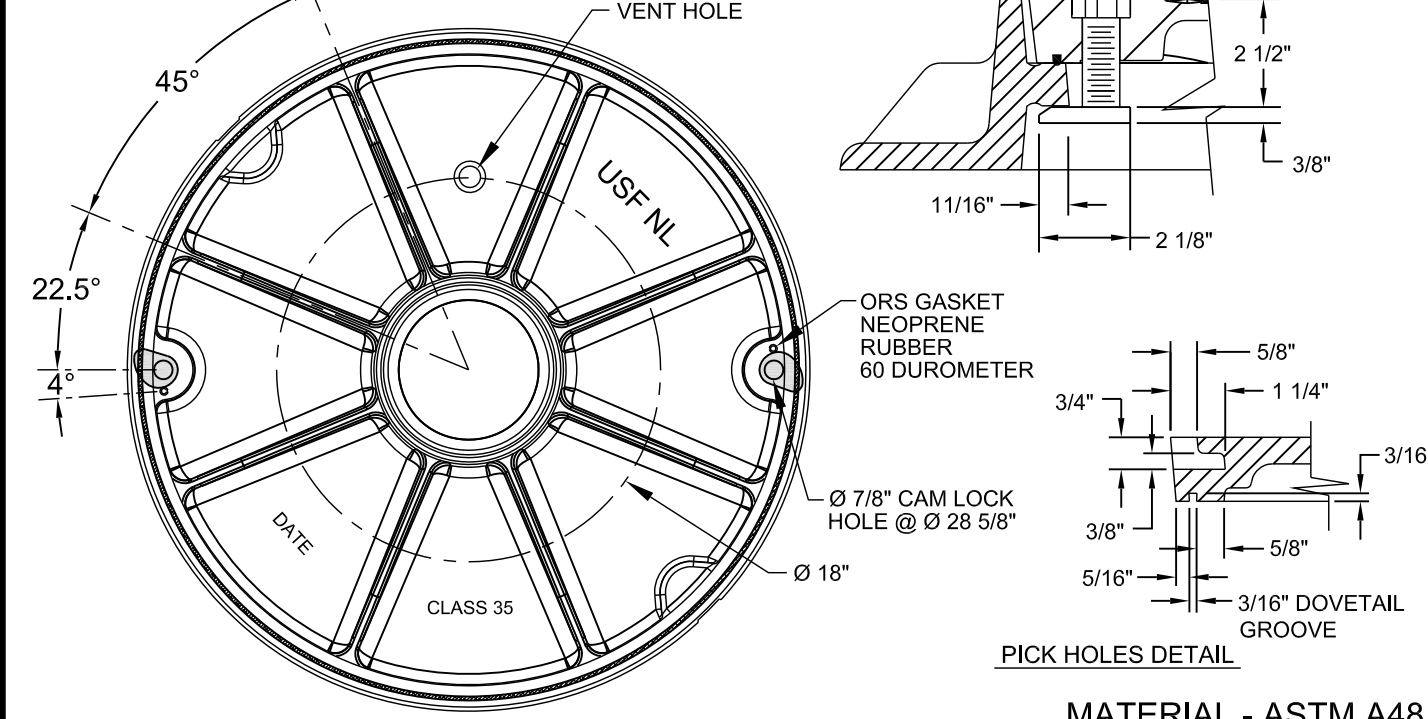
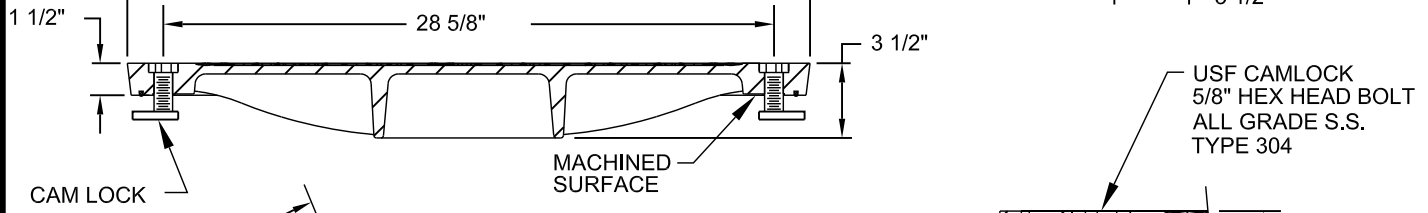
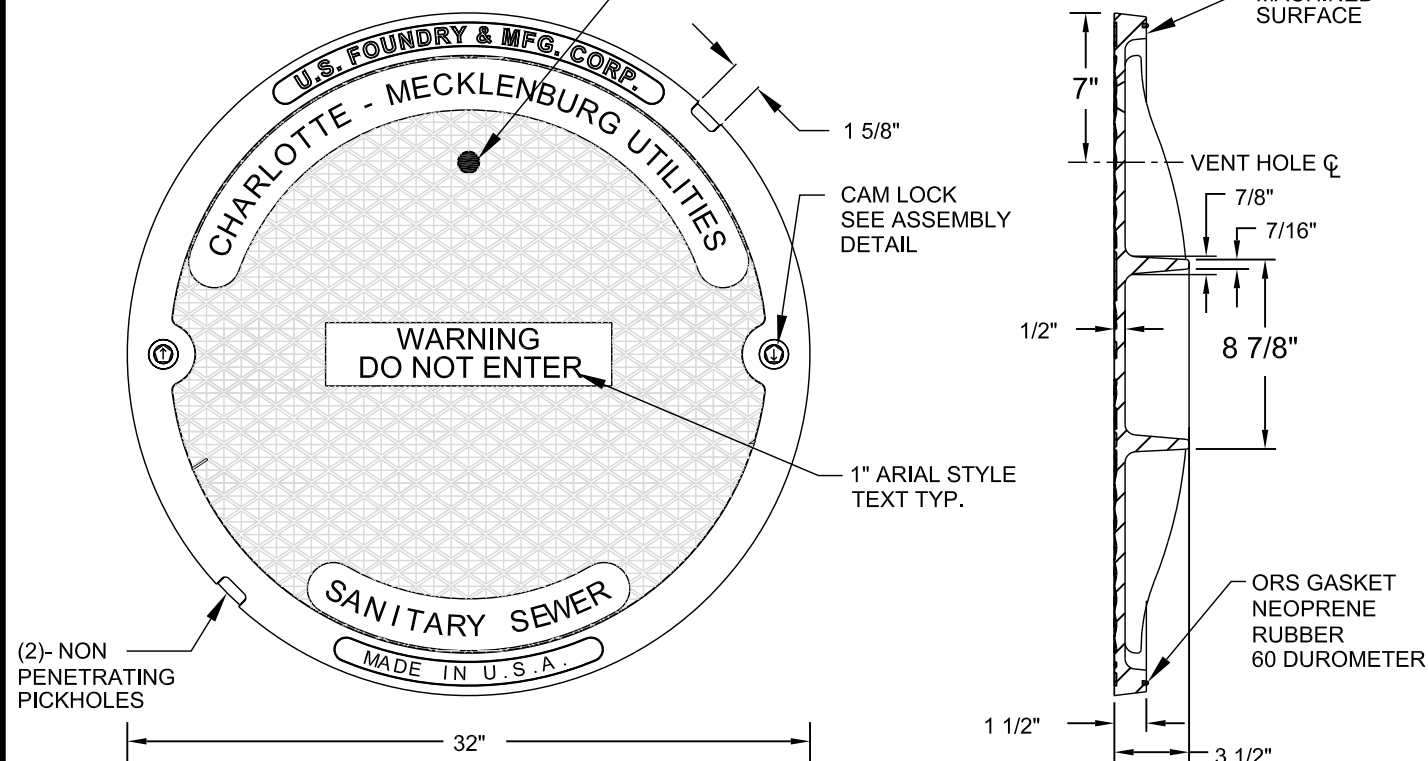

WEIGHT - 165 LB. MIN. , 0% MINUS TOLERANCE

MATERIAL - ASTM A48 CLASS 35

NOTES:

LOAD RATING - HEAVY DUTY
 MATERIAL - DUCTILE OR CAST IRON AS INDICATED ABOVE
 COATING - UNDIPPED

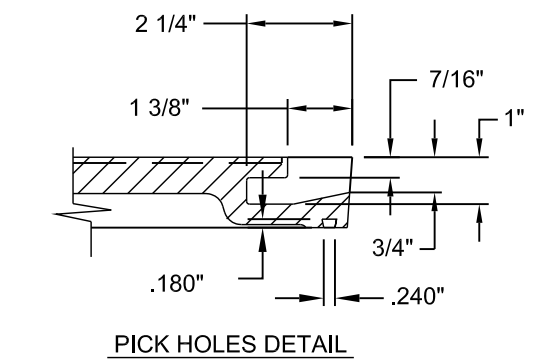
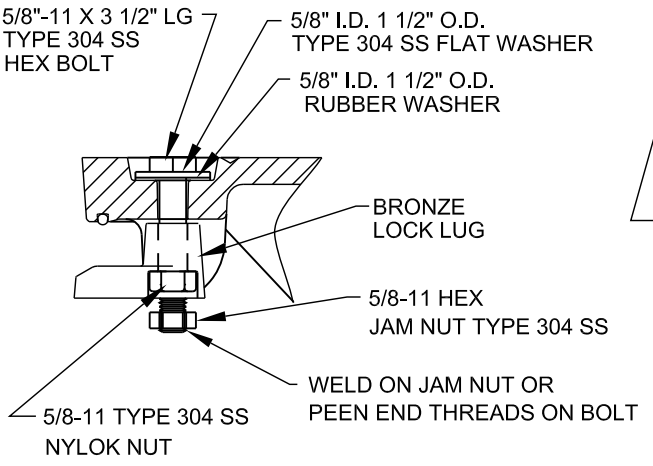
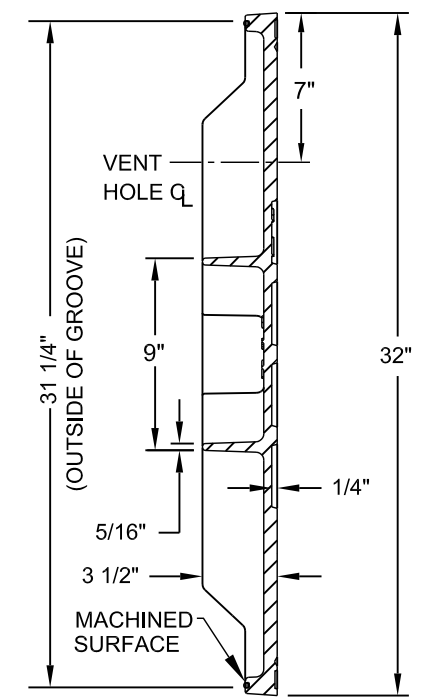

MATERIAL - ASTM A536 DUCTILE IRON - GRADE 80-55-06

EAST JORDAN IRON WORKS

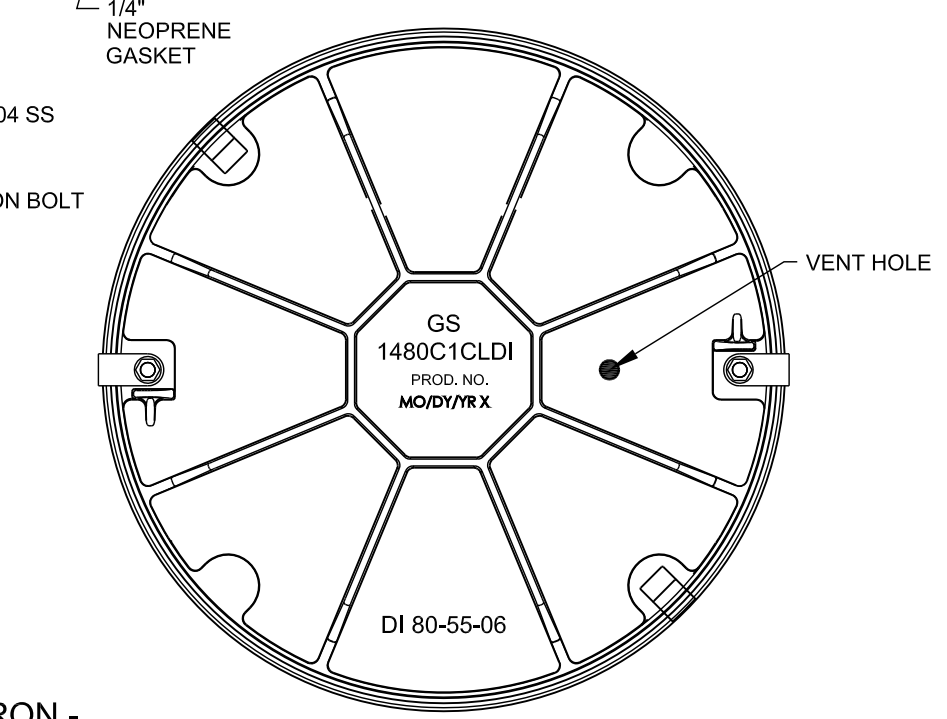
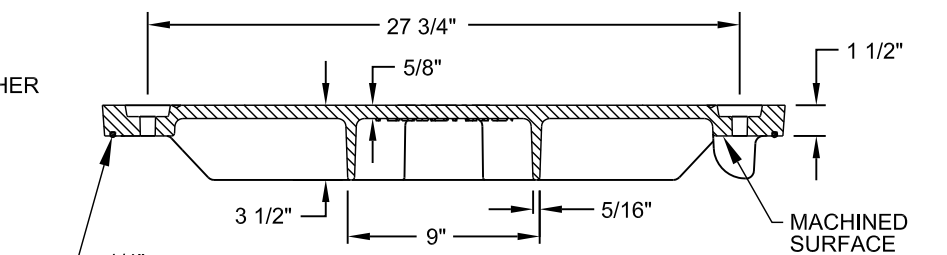
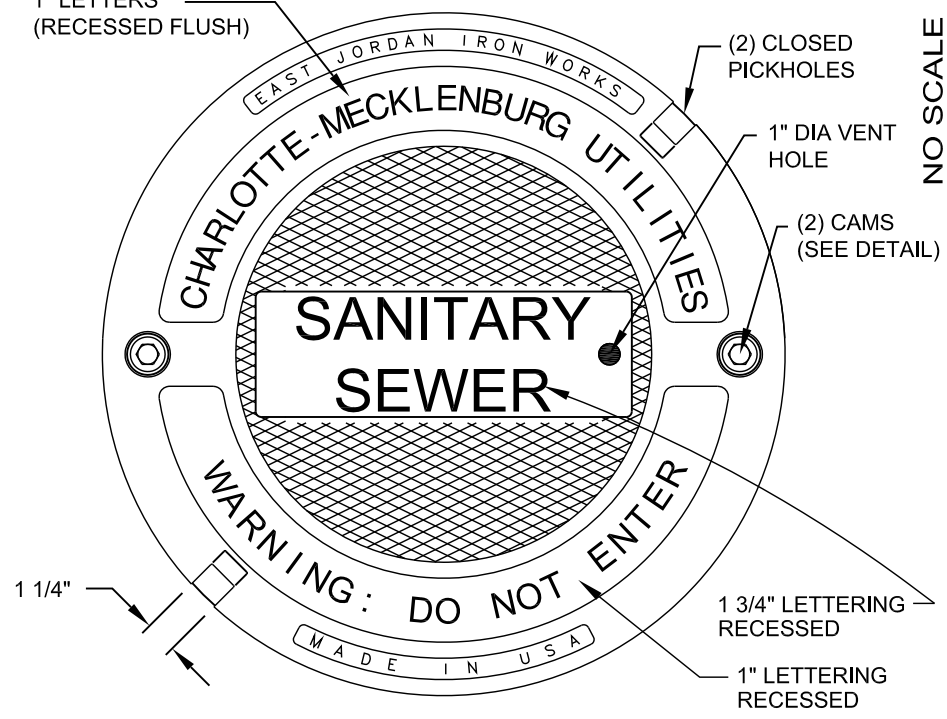

WEIGHT - 150 LB. MIN. , 0% MINUS TOLERANCE

STANDARD NO.	D	VERSION DATE	9.23.2009
VERSION NO.	V1.2		

NO SCALE

TYPE 4 MANHOLE COVER
30-INCHES DIAMETER (CLEAR OPENING)
VENTED - ONE VENT HOLE, GASKET, CAM LOCK

CHARLOTTE-MECKLENBURG UTILITIES
 STANDARD DETAILS
 GRAVITY SEWER

