

U.S. FOUNDRY & MFG. CORP.

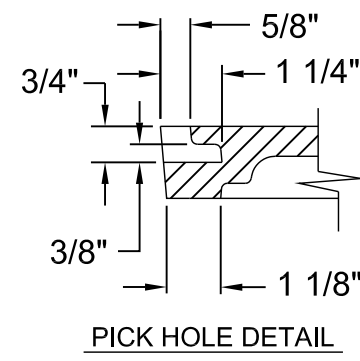
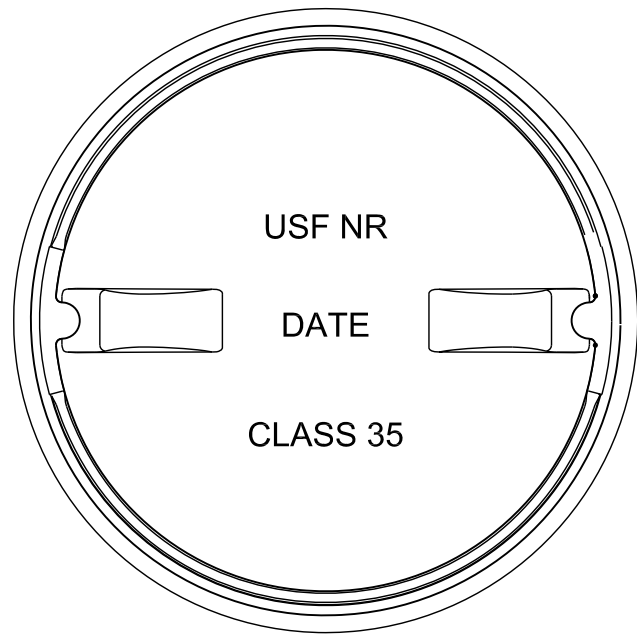
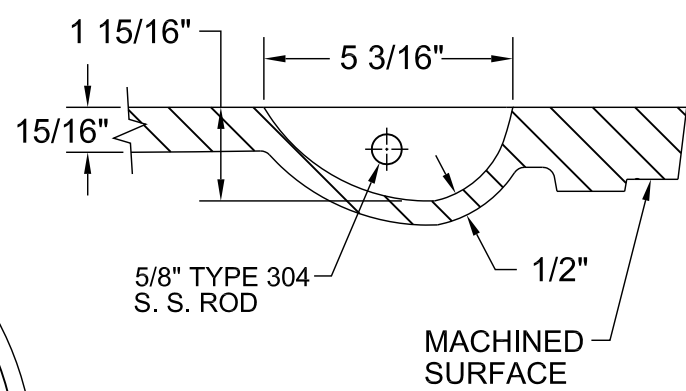
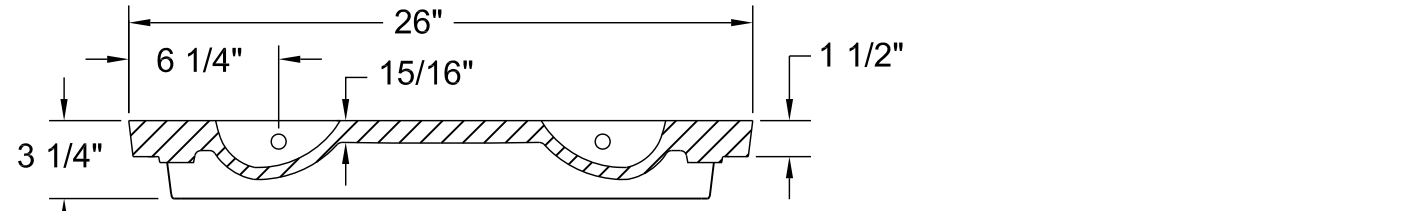
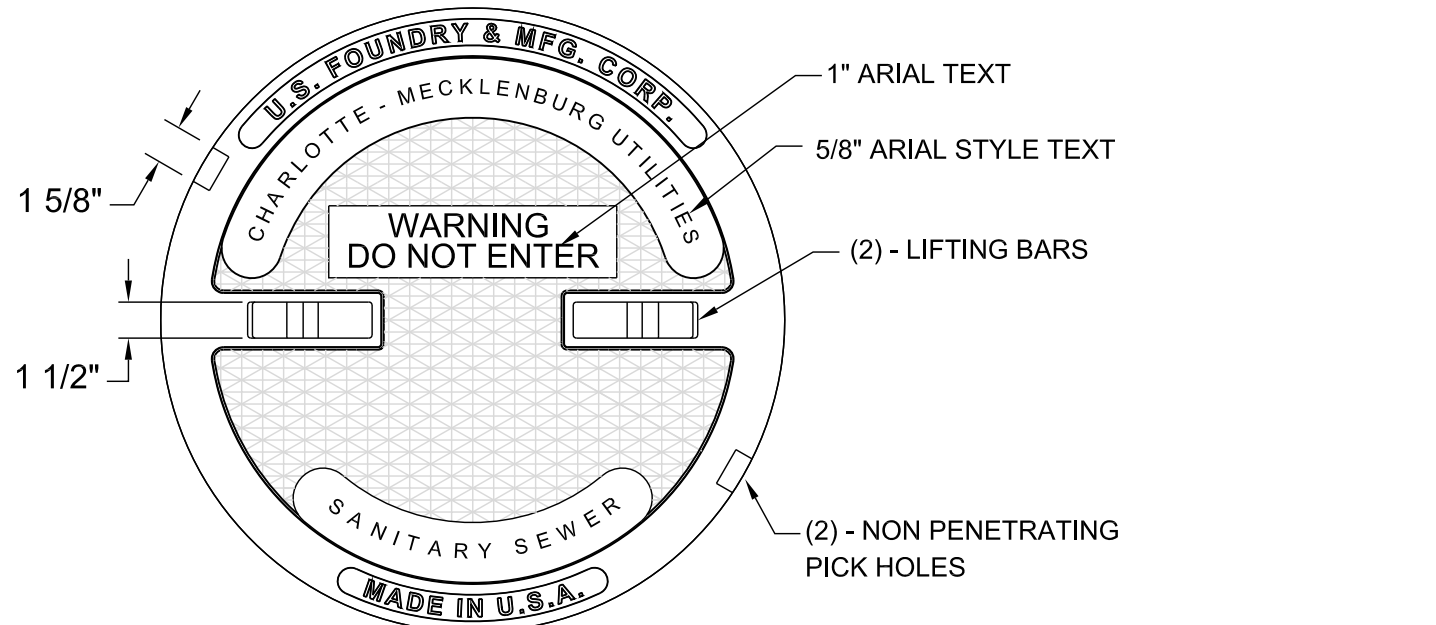

WEIGHT - 150 LB. MIN. , 0% MINUS TOLERANCE

NOTES:

LOAD RATING - HEAVY DUTY
 MATERIAL - ASTM A48 - CLASS 35 GRAY IRON
 COATING - UNDIPPED

EAST JORDAN IRON WORKS

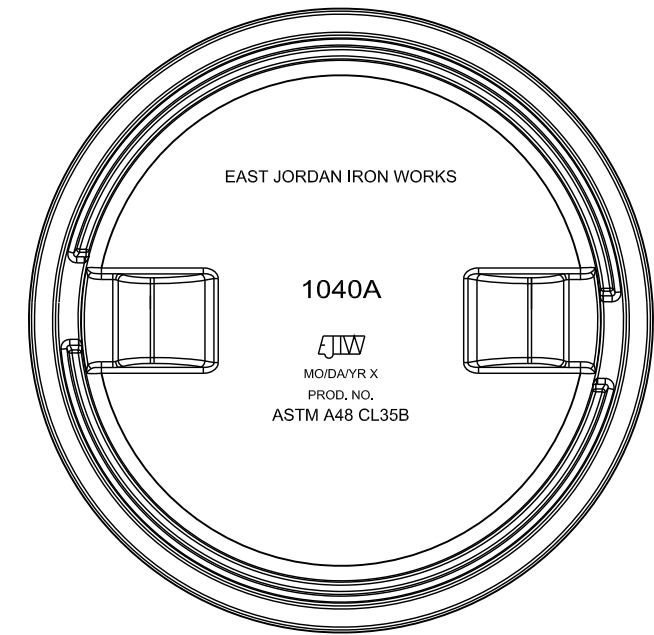
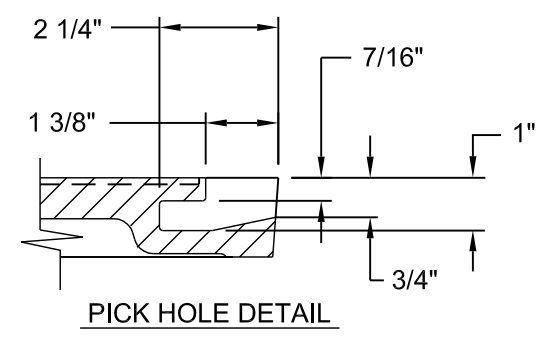
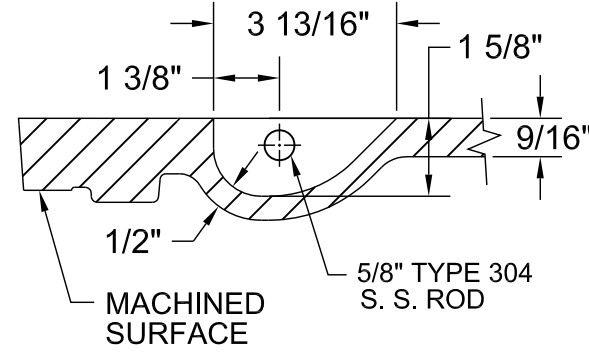
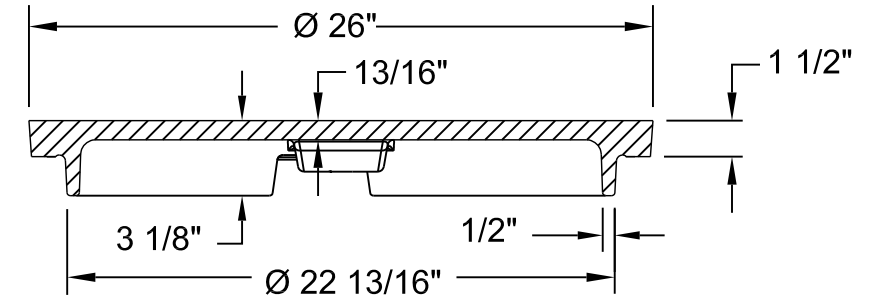
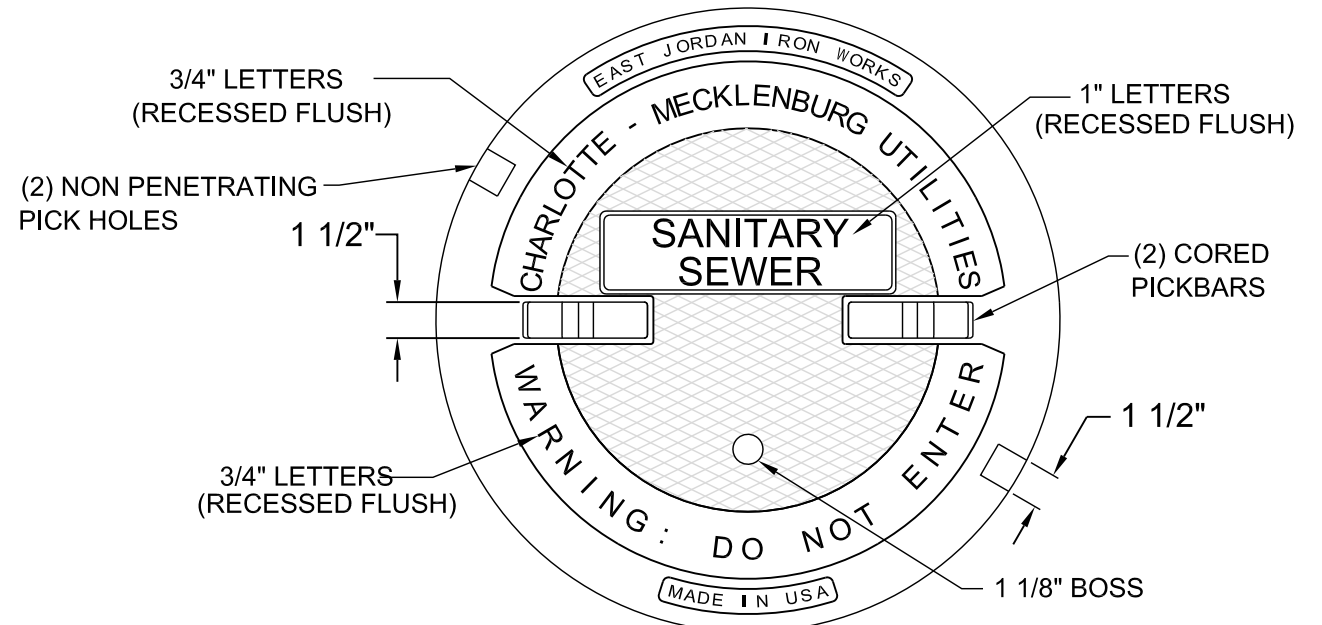

WEIGHT - 145 LB. MIN. , 0% MINUS TOLERANCE

USE WITH TYPE A, B, OR C FRAME
 COVER SHALL CONFORM TO DIMENSION AND WEIGHT REQUIREMENTS.
 COVER SHALL NOT BE OUT OF ROUND.

STANDARD NO.	B
VERSION NO.	V1.2
VERSION DATE	9.23.2009

NO SCALE

TYPE 2 MANHOLE COVER
24-INCHES DIAMETER (CLEAR OPENING)
SOLID - NO VENT HOLE, NO GASKET, NO CAM LOCK

CHARLOTTE-MECKLENBURG UTILITIES
 STANDARD DETAILS
 GRAVITY SEWER

